

## REVIEW

# Cholinergic regulation of epithelial ion transport in the mammalian intestine

CL Hirota and DM McKay

*Department Physiology & Biophysics, University of Calgary, Calgary, AB, Canada*

Acetylcholine (ACh) is critical in controlling epithelial ion transport and hence water movements for gut hydration. Here we review the mechanism of cholinergic control of epithelial ion transport across the mammalian intestine. The cholinergic nervous system affects basal ion flux and can evoke increased active ion transport events. Most studies rely on measuring increases in short-circuit current ( $I_{SC}$  = active ion transport) evoked by adding ACh or cholinomimetics to intestinal tissue mounted in Ussing chambers. Despite subtle species and gut regional differences, most data indicate that, under normal circumstances, the effect of ACh on intestinal ion transport is mainly an increase in  $Cl^-$  secretion due to interaction with epithelial  $M_3$  muscarinic ACh receptors (mAChRs) and, to a lesser extent, neuronal  $M_1$  mAChRs; however, AChR pharmacology has been plagued by a lack of good receptor subtype-selective compounds. Mice lacking  $M_3$  mAChRs display intact cholinergically-mediated intestinal ion transport, suggesting a possible compensatory mechanism. Inflamed tissues often display perturbations in the enteric cholinergic system and reduced intestinal ion transport responses to cholinomimetics. The mechanism(s) underlying this hyporesponsiveness are not fully defined. Inflammation-evoked loss of mAChR-mediated control of epithelial ion transport in the mouse reveals a role for neuronal nicotinic AChRs, representing a hitherto unappreciated braking system to limit ACh-evoked  $Cl^-$  secretion. We suggest that: i) pharmacological analyses should be supported by the use of more selective compounds and supplemented with molecular biology techniques targeting specific ACh receptors and signalling molecules, and ii) assessment of ion transport in normal tissue must be complemented with investigations of tissues from patients or animals with intestinal disease to reveal control mechanisms that may go undetected by focusing on healthy tissue only.

*British Journal of Pharmacology* (2006) **149**, 463–479. doi:10.1038/sj.bjp.0706889; published online 18 September 2006

**Keywords:** acetylcholine; enteric nervous system; intestine; ion transport; muscarinic acetylcholine receptors; nicotinic acetylcholine receptors; short-circuit current; Ussing chambers

**Abbreviations:** AChR, ACh receptor; ATR, atropine; BCh, bethanechol; CCh, carbachol; DMPP, dimethylphenylpiperazinium; EFS, electrical field stimulation; EGF, epidermal growth factor; HEX, hexamethonium; IFN- $\gamma$ , interferon- $\gamma$ ; IHC, immunohistochemistry; mAChR, muscarinic acetylcholine receptor; MP, myenteric plexus; nAChR, nicotinic acetylcholine receptor; PD, potential difference; PG, prostaglandin;  $I_{SC}$ , short-circuit current; SI, small intestine; SMP, submucosal plexus; SP, substance P; TTX, tetrodotoxin; TNF, tumour necrosis factor; VIP, vasoactive intestinal polypeptide; VAChT, vesicular acetylcholine transporter

## Introduction

The epithelial lining of the intestine separates two biological compartments: the gut lumen (i.e. the external environment) from the interstitium. Under normal circumstances, the polarized epithelial cells impede the movement of luminal material into the body and regulate the passage of a variety of substances – nutrients, electrolytes and water – from lumen to body and *vice versa*. The ability to secrete and

absorb electrolytes and fluids is critical to maintain proper hydration of the organism – the intestine and the organs that drain into them (e.g. salivary glands) secrete ~91 of fluid into the lumen daily, most of which (~81) is reabsorbed before it reaches the rectum (Keely and Barrett, 2000). Proper hydration provides the aqueous environment necessary for the processes of contact digestion and nutrient absorption and provides surface lubrication to propel intestinal contents aborally. A properly hydrated gut provides the medium for activity of antimicrobial peptides and movement of water into the lumen contributes to host defence through its ability to flush noxious substances and harmful organisms (e.g. parasites and pathogenic bacteria), thus minimizing their contact with the gut wall. Therefore, regulation of

Correspondence: Dr DM McKay, Department Physiology & Biophysics, University of Calgary, HSc 1877, 3330 Hospital Drive NW, Calgary, AB, Canada T2N 4N1.

E-mail: dmckay@ucalgary.ca

Received 9 May 2006; revised 13 July 2006; accepted 28 July 2006; published online 18 September 2006

water movement is critical from both physiological (i.e. nutrition) and immunological (i.e. host defence) perspectives. If the process of intestinal hydration becomes dysregulated, as during acute intestinal infections or in the context of intestinal inflammation, diarrhoea or constipation can result.

It is not surprising then that water movement into and out of the intestine is highly regulated. There are three known mechanisms by which water can cross the epithelial barrier: (1) absorption along with sodium and glucose via sodium-coupled glucose transporters in the small intestine; (2) specific molecular water channels known as aquaporins; (3) passive osmosis driven by the directed transport of ions across epithelial cells. The expression and function of aquaporins are well described in the kidney, lung, eye and brain (reviewed in King *et al.*, 2004), and their expression and function in the intestinal epithelium is currently the subject of much research (Mobasher *et al.*, 2004; Laforenza *et al.*, 2005a, b). Sodium-coupled glucose transporters and aquaporins are not discussed here, and we refer the reader to recent reviews on these subjects (Loo *et al.*, 2002; Masyuk *et al.*, 2002; Shachar-Hill and Hill, 2002; Matsuzaki *et al.*, 2004). Here, we review control of enteric epithelial ion transport by acetylcholine, drawing attention to species-specific differences, differences in tissues from naïve animals compared to those with disease and comment on putative research directions.

## Intestinal ion transport

Ion transport is an active process driven by electrochemical gradients that are established by the  $\text{Na}^+/\text{K}^+$ -ATPase pump located in the basolateral membrane of polarized epithelial cells. The magnitude, rate and direction of ion flux are dependent on the integrated activity of specific channels, transporters and exchangers asymmetrically expressed on the apical and basolateral cell membranes (Figure 1). The activity of the ion transport machinery is regulated by a variety of compounds signalling through membrane-bound or intracellular receptors to alter levels of intracellular messengers, such as  $\text{Ca}^{2+}$  and cyclic nucleotides.

Study of intestinal ion transport has been greatly facilitated by the development of the Ussing chamber (Ussing and Zerahn, 1951). With this technique, passive flow of ions across a tissue or epithelial cell layer is eliminated by balancing electrical, osmotic, hydrostatic and chemical gradients across the preparation, such that only active ion transport is measured. In the Ussing chamber, electrodes are placed close to each side of the tissue to allow detection of the spontaneous potential difference (PD) across the epithelium, generated as a consequence of active ion transport. The voltage-clamp apparatus matched to the Ussing chamber allows for the PD to be held at a predetermined value by injecting current via two additional silver-silver chloride electrodes, creating a short-circuit current ( $I_{\text{SC}}$ ). Typically, the PD is clamped at zero volts and the amount of injected current required to maintain this reflects the net active ion transport across the preparation. Using the  $I_{\text{SC}}$  and the PD values (obtained by switching

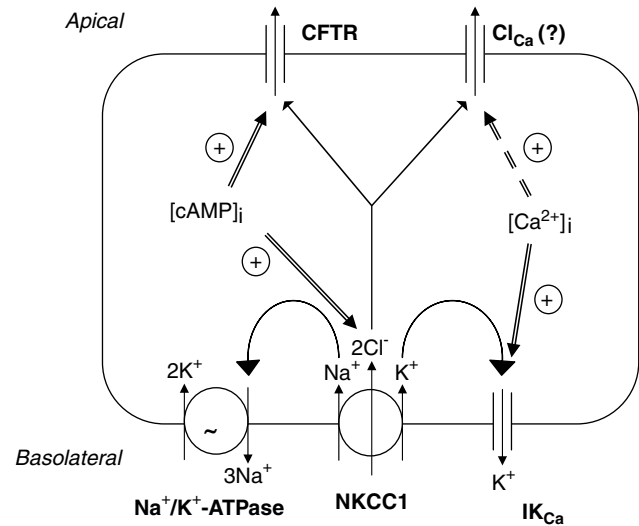

**Figure 1** Schematic representation of the intestinal epithelial  $\text{Cl}^-$  secretory pathway that is upregulated by ACh. The electrochemical gradient is established by the basolateral  $\text{Na}^+/\text{K}^+$ -ATPase pump; this allows entry of  $\text{Na}^+$ ,  $\text{Cl}^-$  and  $\text{K}^+$  through the basolateral membrane via the NKCC1 cotransporter;  $\text{K}^+$  is recycled through basolateral  $\text{K}^+$  channels, one of which is controlled by  $[\text{Ca}^{2+}]_i$ , likely the intermediate conductance  $\text{K}^+$  channel (IK), and  $\text{Cl}^-$  is shunted to the apical membrane, where it exits into the lumen via the apical CFTR  $\text{Cl}^-$  channel and possibly also through an apical  $\text{Ca}^{2+}$ -activated  $\text{Cl}^-$  channel (CaCC, designated  $\text{Cl}_{\text{Ca}}$ ). For additional details, refer to Barrett and Keely (2000).

intermittently to an open certain mode), tissue conductance, which indicates passive ion flow, can be calculated using Ohm's law. By substituting specific ions (e.g. isethionate and acetate for  $\text{Cl}^-$ ) or using radiolabelled ions in the bathing buffers, by selectively blocking or removing specific receptors, channels, exchangers, pumps and transporters, and by blocking non-epithelial cell signalling (e.g. nerve block by tetrodotoxin (TTX), which blocks fast  $\text{Na}^+$  channels on most, but not all, enteric nerves without affecting epithelial  $\text{Na}^+$  channels), the contributions of these components to active electrolyte transport is determined. In the same manner, the effects of nerve stimulation and biological agents (e.g. biogenic amines, bacterial toxins) on active intestinal ion transport can be assessed in tissues or epithelial preparations mounted in Ussing chambers.

## Acetylcholine

One of the most important biological regulators of intestinal ion transport is the major parasympathetic mediator acetylcholine (ACh), which is synthesized by the catalytic conversion of acetyl-CoA and choline to CoA and ACh by choline acetyltransferase (ChAT) (Hebb, 1954; Hebb and Whittaker, 1958). ACh was described as a classical neurotransmitter in the early 1920s (reviewed in Eiden, 1998). More recently, a distinction has been made between ACh as a neurotransmitter and ACh as a signalling molecule in non-neuronal tissue (e.g. blood) and in organisms that lack a nervous system (e.g. protozoa, algae, bacteria, primitive

plants) (Grando *et al.*, 2003; Wessler *et al.*, 2003). As a classical neurotransmitter, ACh synthesis is followed by its transport via the vesicular ACh transporter (VAcHT) to synaptic vesicles, from which it is released *en masse* from nerve terminals as a result of membrane action potentials. However, in non-neuronal cells ACh is not stored in vesicles and its release, which is likely facilitated by organic cation transporters, is continuous and much slower compared to ACh released from nerves (Wessler *et al.*, 2003). In all tissues, ACh is rapidly and specifically degraded by acetylcholinesterase (AChE), although in mammals a second, nonspecific cholinesterase, designated butyrylcholinesterase, which is abundant in the intestine, may also contribute to the degradation of ACh (Massoulié *et al.*, 1993; Li *et al.*, 2000).

As with other neurotransmitters, direct measurement of ACh can be accomplished through microdialysis followed by high-performance liquid chromatography: this method has been applied in the intestine (Furuichi *et al.*, 2001). However, owing to the difficulty and invasiveness of this technique and because ACh does not lend itself to reliable fixation for detection in preserved tissues, the presence of ACh is often inferred based on expression of the enzymatic components of the cholinergic pathway (Eckenstein and Thoenen, 1982). Analyses of ChAT and VAcHT are more accurate than AChE for determining the presence of ACh, as the breakdown of ACh need not occur in the same location as its production. Additionally, VAcHT is only relevant to neuronal ACh, leaving ChAT as the universal surrogate for ACh. ChAT activity can be determined radiochemically in tissue homogenates and the protein localized by immunohistochemistry (IHC) with commercial antibodies (Fonnum, 1975; Eckenstein and Thoenen, 1982; Sharkey *et al.*, 1998).

Neuronal cholinergic networks, as defined by IHC detection of ChAT, relating to the control of intestinal motility and, to a lesser extent, ion secretion have been extensively studied in the guinea-pig (Costa *et al.*, 2000; Furness, 2000; Brookes, 2001; Bornstein *et al.*, 2004). Although enteric nerve signalling is well defined in the guinea-pig (Brown and Timmermans, 2004), it is important that this information be complemented by delineation of cholinergic pathways in mammalian species commonly used as models of human intestinal (patho)physiology/disease. Table 1 details the enteric localization of ACh in several mammalian species, including humans. The divide between ACh as a neurotransmitter and ACh as a signalling molecule is especially apparent in the intestine and cholinergic pathways exhibit regional differences along the length of the intestine. Also, while several cholinergic pathways are conserved across species, there are differences between species, one notable example being the colocalization of ChAT and vasoactive intestinal polypeptide (VIP) in secretomotor neurons of the submucosal plexus (SMP) in humans (Schneider *et al.*, 2001), a pattern not observed in guinea-pigs at least. Although the enteric nervous system can be considered a discrete entity, cholinergic input from extrinsic nerves that project fibres into the gut (i.e. vagus and pelvic splanchnic nerves) should be recognized as a component in the bigger picture perspective of cholinergic control of physiological events in the gut.

## Acetylcholine receptors and pharmacology

ACh receptors (AChRs) fall into two categories: metabotropic G-protein-coupled muscarinic receptors, of which there are five known subtypes, M<sub>1</sub>–M<sub>5</sub>, and ionotropic nicotinic receptors, which are made up of five subunits that may be in homomeric or heteromeric combinations. Muscarinic (mAChRs) and nicotinic AChRs (nAChRs) are expressed on neuronal as well as on non-neuronal cells in the gut (Tables 2 and 3). Signalling pathways and functions associated with mAChRs have been reviewed in detail elsewhere (Caulfield, 1993; Lanzafame *et al.*, 2003).

Briefly, odd numbered mAChRs couple to G<sub>q/11</sub>  $\alpha$  subunits to activate phospholipase C (PLC), whereas even numbered mAChRs couple to the G<sub>i</sub>  $\alpha$  subunit to inhibit adenylate cyclase. Activation of the PLC pathway leads to degradation of membrane-bound phosphatidylinositol 4,5-bisphosphate (PIP<sub>2</sub>) into diacyl glycerol (DAG) and inositol-1,4,5 triphosphate (IP<sub>3</sub>), which, together, lead to activation of protein kinase C (PKC) and increased levels of intracellular Ca<sup>2+</sup> as the main outcome. nAChRs are allosteric ion channel proteins that are permeable to monovalent cations and, to a lesser extent, Ca<sup>2+</sup>. Binding of an agonist (i.e. ACh) to nAChRs preferentially stabilizes it in an open or active conformational state. Subsequent entry of cations through the open channel depolarizes the cell membrane, thus contributing, in the case of a neuron, to the generation of an action potential. The structure and function of nAChRs has been described in detail in the context of the central nervous system and the neuromuscular junction (Hogg *et al.*, 2003; Gotti and Clementi, 2004).

Several agonists of AChRs mimic the effects of ACh and are often used in its place experimentally because they are less susceptible than ACh to degradation by AChE. However, mAChR agonists, including ACh, are not highly subtype selective and this needs to be appreciated when evaluating the data from studies relying on these reagents (Hulme *et al.*, 1990). Additionally, some mAChR agonists, such as pilocarpine, McN A-343 and, surprisingly, even ACh and bethanechol (BCh), may behave as partial, rather than full, agonists in some experimental systems (Yule *et al.*, 1993; Sharif *et al.*, 1995). Receptor subtype selectivity has also been a problem with commonly used mAChR antagonists (Hulme *et al.*, 1990). However, the characterization of toxins isolated from the venom of mamba snakes has provided several compounds that are highly selective toward the M<sub>1</sub> and M<sub>4</sub> subtypes of mAChRs (see Table 4; reviewed in Karlsson *et al.*, 2000). For an extensive discussion of mAChR pharmacology and associated physiology, refer to Caulfield (1993), Eglén *et al.* (1996), Caulfield and Birdsall (1998) and Eglén (2005).

nAChR pharmacology is complicated by the fact that, while at least 11 genes have been identified for mammalian non-muscle nAChR subunits ( $\alpha$ 2– $\alpha$ 7,  $\alpha$ 9– $\alpha$ 10,  $\beta$ 2– $\beta$ 4), not all of the subunit combinations natively expressed in different tissues and species are known (Nicke *et al.*, 2004). Generally, the  $\alpha$ 4,  $\beta$ 2 and  $\alpha$ 7 subunits predominate in the central nervous system, whereas  $\alpha$ 3,  $\beta$ 4 and  $\alpha$ 7 subunits are common in the peripheral nervous system.  $\alpha$ 7 subunit-containing receptors occur in homomeric combination, whereas  $\alpha$ 4,  $\alpha$ 3,  $\beta$ 2 and  $\beta$ 4 subunits occur in heteromeric combinations of

**Table 1** Localization of ACh production in the mammalian gut

Species	Tissue	ChAT/VACHT-positive cell types <sup>a</sup>	References
Guinea-pig	Small intestine	MP: Excitatory muscle motor neurons, Ascending interneurons to excitatory circular muscle motor neurons of MP, <b>descending interneurons</b> (three types that all are ChAT-IR – those containing ChAT/5-HT are involved in secretomotor reflex), <b>IPANs</b> (mucosal varicose processes likely release ACh), intestinofugal nerves to prevertebral ganglia SMP: <b>Secretomotor/vasodilator neurons, secretomotor (non-vasodilator) neurons, IPANs</b> (mucosal varicose processes likely release Ach)	McMurray <i>et al.</i> (1993), Neunlist <i>et al.</i> (1999), Costa <i>et al.</i> (2000), Furness (2000), Brookes (2001), Furness <i>et al.</i> (2004), Harrington <i>et al.</i> (2005)
	Large intestine	MP: Ascending neurons, <b>IPANs</b> , excitatory muscle motor neurons SMP: Ascending secretomotor/vasodilator neurons, <b>secretomotor neurons</b> EC cells of small intestine	
Mouse	Small intestine	MP: ~60–65% of neurons; including Excitatory muscle motor neurons, Descending interneurons SMP: ~40% of neurons; includes likely secretomotor neurons, secretomotor/vasodilator neurons	Sang and Young (1998)
	Large intestine	MP: ~55% of neurons; includes excitatory muscle motor neurons, descending interneurons SMP: ~20% of neurons; includes likely secretomotor neurons, secretomotor/vasodilator neurons <i>Note:</i> ChAT-IR EC cells observed in both SI and LI; ChAT- and VACHT-IR nerve terminals observed throughout MP, SMP, muscle layers, at the base of glands and associated with submucous blood vessels in both SI and LI	
Rat	Small and large intestine	MP: Nerve cell bodies and fibres (unidentified subtypes) SMP: Nerve cell bodies and fibres (unidentified subtypes) EC cells of small intestine	McMurray <i>et al.</i> (1993)
Pig	Small intestine	MP: ~80% of total traced neurons; includes IPANs, excitatory muscle motor neurons, secretomotor neurons, descending interneurons, intestinofugal neurons OSP: ~85% of total traced neurons; includes IPANs, excitatory muscle motor neurons, secretomotor neurons, descending interneurons, intestinofugal neurons ISP: ~25% of total traced neurons; includes IPANs and secretomotor neurons Nerve fibres within circular muscle layer; cell bodies and fibres at the margins of PP follicles; occasional fibres within PP follicles and domes and adjacent to submucosal blood vessels; neurons of interfollicular ganglia, <i>Note:</i> minor discrepancies between jejunum and ileum	Kulkarni-Narla <i>et al.</i> (1999), Hens <i>et al.</i> (2000), Brown and Timmermans (2004)
Human	Small and large intestine	MP: Excitatory muscle motor neurons, descending interneurons, ascending interneurons, IPANs SMP: Secretomotor neurons EC cells, T cells	Porter <i>et al.</i> (1996), Kawashima and Fujii (2000), Porter <i>et al.</i> (2002), Schemann and Neunlist (2004)

Abbreviations: EC, enterochromaffin; IPANs, intrinsic primary afferent neurons; IR, immunoreactive; ISP, inner submucosal plexus; LI, large intestine; MP, myenteric plexus; OSP, outer submucosal plexus (ISP and OSP are subdivisions of SMP found in larger mammals, i.e. pig); PP, Peyer's patch; SI, small intestine; SMP, submucosal plexus.

<sup>a</sup>Bold text indicates neurons believed to be involved in intestinal secretion and secretory reflexes in the guinea-pig.

both  $\alpha$  and  $\beta$  subunits (Gotti and Clementi, 2004). A few compounds are able to distinguish between homomeric  $\alpha 7$  nAChRs and non- $\alpha 7$ -containing nAChRs, most notably the snake venom component  $\alpha$ -bungarotoxin and methyllycaconitine. Both compounds competitively and selectively antagonize homomeric  $\alpha 7$  nAChRs (Davies *et al.*, 1999). *Conus* snail venom has also provided several potentially competitive nAChR antagonists, the  $\alpha$ -conotoxins, which show subtype selectivity for specific known subtype combinations, although it is unknown if this subtype selectivity applies to all species (Nicke *et al.*, 2004). Non-competitive antagonists of nAChRs include the archetypal ganglionic blockers mecamlamine and hexamethonium (HEX), which demonstrate relatively low affinity for nAChRs ( $K_i$  values in the mM range) (Macallan *et al.*, 1988; Davies *et al.*, 1999).

Table 4 lists the affinities of several major AChR agonists and antagonists for specific AChR subtypes. Table 5 lists

the affinities of mAChR agonists and antagonists that have been determined in intestinal tissue from a few different species. These drugs have been instrumental in profiling mAChR subtypes involved in intestinal ion transport. Subtype characterization of nAChRs involved in intestinal ion transport has been hindered by a lack of knowledge of the precise nAChR subtypes expressed in the gut. Details of nAChR involvement in intestinal ion transport requires better characterization of the receptor subtypes expressed in the gut before pharmacology can be fully validated. It should be cautioned that, when dealing with promiscuous compounds (i.e. the majority of mAChR ligands), studies using only one compound to implicate the involvement of a specific receptor subtype are not reliable – AChR subtype characterization requires a diverse array of pharmacological tools. Thus, ACh receptor subtype involvement inferred from the use of poorly selective

**Table 2** Non-pharmacological demonstration of muscarinic ACh receptors in the mammalian gut

Species	Tissue	Receptor subtype detected	Cell type/tissue region	Method	References
Rabbit	Ileum	M <sub>1</sub> (3%) <sup>a</sup> , M <sub>2</sub> (69%), M <sub>3</sub> (4%), M <sub>4</sub> (12%), M <sub>5</sub> (0%)	ND	IP	Dorje <i>et al.</i> (1991a)
Mouse	Ileum	M <sub>2</sub> , M <sub>4</sub>	Circular and longitudinal smooth muscle (M <sub>2</sub> only); M <sub>2</sub> and M <sub>4</sub> colocalization in cell bodies and fibres of ChAT-positive myenteric neurons	IF	Takeuchi <i>et al.</i> (2005), Haberberger <i>et al.</i> (2006)
	Colon	M <sub>1</sub>	Epithelium	RT-PCR	
Rat	Ileum	M <sub>1</sub> (17%), M <sub>2</sub> (69%), M <sub>3</sub> (7%)	Epithelial cells (adult and fetal), including endocrine L cells	IF; IP	Wall <i>et al.</i> (1991), Levey (1993), Anini <i>et al.</i> (2002)
	Colon	M <sub>4</sub>	Nerve fibres (likely presynaptic)	IHC	
Sheep	Ileum	M <sub>1</sub> , M <sub>2</sub> , M <sub>3</sub> , M <sub>4</sub> , M <sub>5</sub>	Adult smooth muscle	IHC	Oyachi <i>et al.</i> (2003)
Pig	Ileum	M <sub>2</sub> , M <sub>3</sub>	Smooth muscle	NB	Maeda <i>et al.</i> (1988)
Human	Ileum	M <sub>3</sub>	Mucosa (adjacent to epithelium), muscularis mucosa, submucosal blood vessels	IF	Sato <i>et al.</i> (1999), Oue <i>et al.</i> (2000), Lindqvist <i>et al.</i> (2002), Anini and Brubaker (2003), Banks <i>et al.</i> (2004)
	Colon (juvenile)	M <sub>1</sub> , M <sub>2</sub> , M <sub>3</sub> M <sub>2</sub> , M <sub>3</sub>	Epithelial cells, endocrine L cells Mucosal layer, smooth muscle, cell bodies and fibres of myenteric plexus neurons	IF IHC; ISH	
	Colon	M <sub>1</sub>	Mucosal layer	IHC	
	Blood	M <sub>3</sub>	Crypt epithelial cells	IF	
	Cultured cell lines	M <sub>1</sub> , M <sub>2</sub> , M <sub>3</sub> , M <sub>4</sub> , M <sub>5</sub> M <sub>1</sub> , M <sub>2</sub> , M <sub>3</sub> M <sub>1</sub> , M <sub>2</sub> , M <sub>3</sub> , M <sub>4</sub> , M <sub>5</sub>	MNL; <i>Note:</i> variable expression of M <sub>1</sub> –M <sub>3</sub> among subjects NCI-H716 endocrine L cells CEM, MOLT-3, HUT-78, HPB-ALL and Jurkat T cells; <i>Note:</i> variable expression of M <sub>1</sub> –M <sub>3</sub> among cell lines	RT-PCR RT-PCR RT-PCR	
		M <sub>1</sub> , M <sub>2</sub> , M <sub>3</sub> , M <sub>4</sub> , M <sub>5</sub>	BALL-1, Daudi and NALM-6 B cells; <i>Note:</i> variable expression of M <sub>1</sub> –M <sub>3</sub> among cell lines	RT-PCR	

Abbreviations: IF, immunofluorescence; IHC, immunohistochemistry; IP, immunoprecipitation; ISH, *in situ* hybridization; MNL, mononuclear leukocytes; NB, Northern blot; ND, not determined; RT-PCR, reverse transcription-polymerase chain reaction; WB, Western blot.

<sup>a</sup>Percentage of total receptors precipitated (IP experiments performed in whole tissue).

antagonists and/or partial agonists should be verified using newer, more selective drugs and with molecular biology techniques, such as gene targeting strategies to delete specific AChR subtypes (as reviewed in Wess (2004) for mAChRs).

### Cholinergic control of enteric epithelial ion transport

#### Baseline ion transport

Typically, the baseline active ion transport of normal mammalian intestinal tissue, as demonstrated by  $I_{SC}$ , reflects a negative charge on the luminal side and positive charge on the serosal side of the tissue (Field, 1974). Absorption of Na<sup>+</sup> and Cl<sup>-</sup> typically accounts for most of this baseline ion transport; the relative contributions of K<sup>+</sup>, HCO<sub>3</sub><sup>-</sup> and H<sup>+</sup> vary according to intestinal region and species. Numerous studies indicate that baseline epithelial transport is in part due to tonic nerve activity, and this is via neurons of the SMP (Furness, 2000; Vanner and MacNaughton, 2004), with a small contribution from secretomotor neurons that project

from the myenteric plexus into the mucosa (Costa *et al.*, 2000). This concept is supported by the fact that gut preparations stripped of the outer muscle layers and attendant myenteric plexuses still display positive baseline  $I_{SC}$  values.

Additional evidence in support of neural control of baseline  $I_{SC}$  is provided by consideration of the effect of the neuronal blocker TTX, which can elicit a drop in baseline  $I_{SC}$ . For instance, TTX applied to muscle-stripped segments of porcine distal jejunum produces a dramatic drop in baseline  $I_{SC}$ , although this effect is less pronounced in the proximal jejunum (Rangachari and McWade, 1986; Hildebrand and Brown, 1990; Chandan *et al.*, 1991a, b). Similarly, TTX treatment reduces the baseline  $I_{SC}$  across muscle-stripped dog, rabbit and porcine colon and full-thickness mouse jejunum and colon (Sheldon *et al.*, 1989; Biagi *et al.*, 1990; Traynor *et al.*, 1991; Sayer *et al.*, 2002). Data in favour of, and refuting, the ability of TTX to lower baseline  $I_{SC}$  in muscle-stripped human left/sigmoid colon has been presented (Hubel *et al.*, 1987; Kuwahara *et al.*, 1989), and, in support of the latter, TTX treatment does not alter baseline  $I_{SC}$  in the rat colon (Zimmerman and Binder, 1983). It is difficult to

**Table 3** Non-pharmacological demonstration of nicotinic ACh receptors in the mammalian gut

Species	Tissue	Receptor subunits detected	Cell type/tissue region	Method	References
Guinea-pig	Ileum and Colon	$\alpha 3, \alpha 5, \beta 4$ (?)	Nerve cell bodies and fibres – MP (more abundant staining in colon): inhibitory and excitatory motor neurons, secretomotor neurons, afferent and/or ascending interneurons; SMP: secretomotor neurons, interneurons	IF; IHC	Kirchgessner and Liu (1998), Obaid <i>et al.</i> (1999), Zhou <i>et al.</i> (2002), Glushakov <i>et al.</i> (2004)
		$\beta 2$ $\alpha 7$	EC cells SMP neurons of small intestine	IF; IHC IF; IHC	
	Cultured cells	$\alpha 3, \alpha 5, \beta 4$ (?), $\beta 2, \alpha 7$	Primary cultured MP neurons of small intestine (only a few neurons positive for $\alpha 7$ ); <i>Note</i> : colocalization of nAChR subunits with cholinergic and non-cholinergic neurons	IF	
Human	Ileum and Colon	$\alpha 3, (\alpha 5, \beta 4$ ?)	MP and SMP neurons and fibres traversing smooth muscle; Epithelium; Lymphoid tissue; <i>Note</i> : variable distribution among subjects	ISH; IHC	Hiemke <i>et al.</i> (1996), Battaglioli <i>et al.</i> (1998), Sato <i>et al.</i> (1999), Richardson <i>et al.</i> (2001), Richardson <i>et al.</i> (2003), Summers <i>et al.</i> (2003)
	Blood	$\alpha 3, \alpha 4$	CD4 <sup>+</sup> Lymphocytes; <i>Note</i> : variable expression among subjects	ISH; IHC	
		$\alpha 2, \alpha 5, \alpha 6, \alpha 7, \beta 2$	MNL; <i>Note</i> : variable expression of $\alpha 6$ and $\beta 2$ among subjects	RT-PCR	
	Cultured cell lines	$\alpha 4, \alpha 5, \alpha 7, \beta 1$	HT29 colonic epithelial cell line	RT-PCR	
		$\alpha 3$ $\alpha 2, \alpha 3, \alpha 5, \alpha 6, \alpha 7, \beta 4$ $\alpha 2, \alpha 5, \alpha 6, \alpha 7, \beta 2, \beta 4$	Jurkatt and MOLT-4T cells CEM, MOLT-3, HUT-78, HPB-ALL and Jurkat T cells BALL-1, Daudi and NALM-6 B cells	NB RT-PCR RT-PCR	

Abbreviations: EC, enterochromaffin; IHC, immunohistochemistry; IF, immunofluorescence; ISH, *in situ* hybridization; MNL, mononuclear leukocytes; MP, myenteric plexus; NB, Northern blot; SMP, submucosal plexus.

determine the source of variability in these studies: differences in tissue preparation, subtle region-specific differences or environmental variability (i.e. diet, resident intestinal flora) are possibilities. Moreover, use of TTX gives no indication of the phenotype of neuron, or the possibility of signalling within the ENS via interneurons that impacts upon baseline  $I_{SC}$ . Also, analyses of the role of neurons in the control of epithelial ion transport should, for example, be complemented by identification of the ion fluxes responsible for the TTX effect.

Although technically demanding, some enteric tissues (e.g. dog colon) can be stripped of both the outer muscle layers and the submucosa, leaving sheets of epithelial crypts and a supporting basement membrane. [It should be noted that the procedure to remove the muscle and mounting in the Ussing chamber have the potential to activate stretch receptors that could elicit intracellular and intercellular signalling cascades that could affect active ion transport across the enterocyte.] These preparations maintain active ion transport that is unaffected by TTX, although baseline  $I_{SC}$  values are lower than in preparations containing an intact submucosa (Rangachari and McWade, 1986; Diener *et al.*, 1989). Monolayers of human colon-derived epithelial cell lines (i.e. T84 cells, HT-29 cells, Caco-2 cells) also exhibit baseline ion transport in the absence of any neural input, demonstrating that whereas enteric nerves modulate epithelial baseline active ion transport, the enterocyte itself is primarily responsible for the generation of driving forces to support vectorial ion movements. Thus, baseline production of intracellular ATP allows for energy-dependent ionic

gradients to be established while other mediators, such as cAMP, positively regulate the opening of apical and basolateral ion channels. Other non-neuronal mediators present in the mucosa (e.g. prostaglandins (PGs); Craven and DeRubertis, 1983) probably also contribute to baseline levels of active ion transport, although this has mostly been studied in the context of stimulated ion transport (see following sections).

Using atropine (ATR) as the gold standard mAChR antagonist has revealed contrasting data in terms of cholinergic input to tonic enteric epithelial  $I_{SC}$ . Thus, full thickness mouse colon, muscle-stripped rat colon and porcine jejunum respond to ATR treatment with a decrease in  $I_{SC}$  (Diener *et al.*, 1989; Chandan *et al.*, 1991b; Sayer *et al.*, 2002). Contrarily, treatment with ATR does not affect baseline  $I_{SC}$  in guinea-pig small bowel, porcine jejunum, and rabbit and human colon (Cooke, 1984; Keast *et al.*, 1985; Hubel *et al.*, 1987; Kuwahara *et al.*, 1989; Biagi *et al.*, 1990; Hildebrand and Brown, 1990; Chandan *et al.*, 1991b). Few studies have assessed the impact of nAChR antagonists on baseline  $I_{SC}$ : porcine jejunum, mouse mid-colon and rat distal colon all display small but consistent reductions in baseline  $I_{SC}$  following treatment with HEX (Hildebrand and Brown, 1990; Sun *et al.*, 2000; Sayer *et al.*, 2002), although this effect requires high (100  $\mu$ M) concentrations of HEX in the porcine jejunum (Hildebrand and Brown, 1990; Chandan *et al.*, 1991a).

Collectively, the data support the contention that the enteric nervous system contributes to baseline epithelial ion transport, albeit to varying degrees between species and

**Table 4** Affinity profiles of AChR agonists and antagonists for known AChR subtypes

Drug	$K_i$ (nM)	References
<b>mAChR agonist</b>		
Carbachol	205 (M <sub>1</sub> ), 93.4 (M <sub>3</sub> ), 35.7 (M <sub>5</sub> ) <sup>a</sup>	Kukkonen <i>et al.</i> (1996)
<b>mAChR antagonist</b>		
AF-DX 116	1300 (M <sub>1</sub> ), 186 (M <sub>2</sub> ), 838 (M <sub>3</sub> ), 2800 (M <sub>5</sub> ) <sup>b</sup>	Buckley <i>et al.</i> (1989), Billard <i>et al.</i> (1995)
AF-DX 384	344.6 (M <sub>1</sub> ), 32.4 (M <sub>2</sub> ), 198.6 (M <sub>3</sub> ), 123.5 (M <sub>4</sub> ) <sup>b</sup>	Dorje <i>et al.</i> (1991b)
Atropine	30.9 (M <sub>1</sub> ), 6.03 (M <sub>2</sub> ), 66.1 (M <sub>3</sub> ), 10.0 (M <sub>4</sub> ), 537.0 (M <sub>5</sub> ) <sup>b</sup>	Buckley <i>et al.</i> (1989), Moriya <i>et al.</i> (1999)
4-DAMP, 4-diphenylacetoxyl- <i>N</i> -methylpiperidine methiodide	0.21 (M <sub>1</sub> ), 1.5 (M <sub>2</sub> ), 0.15 (M <sub>3</sub> ), 0.21 (M <sub>5</sub> ) <sup>b</sup>	Dorje <i>et al.</i> (1991b), Moriya <i>et al.</i> (1999)
Hexahydro-sila-difenidol	0.28 (M <sub>1</sub> ), 0.76 (M <sub>2</sub> ), 0.19 (M <sub>3</sub> ), 0.13 (M <sub>4</sub> ), 0.24 (M <sub>5</sub> ) <sup>a</sup>	Dorje <i>et al.</i> (1991b), Moriya <i>et al.</i> (1999)
Hexocyclium	0.58 (M <sub>1</sub> ), 3.8 (M <sub>2</sub> ), 0.52 (M <sub>3</sub> ), 1.27 (M <sub>4</sub> ), 1.05 (M <sub>5</sub> ) <sup>b</sup>	Dorje <i>et al.</i> (1991b)
Himbacine	0.57 (M <sub>1</sub> ), 7.3 (M <sub>2</sub> ), 0.37 (M <sub>3</sub> ), 0.72 (M <sub>4</sub> ), 0.55 (M <sub>5</sub> ) <sup>a</sup>	Buckley <i>et al.</i> (1989)
Methoctramine	22.4 (M <sub>1</sub> ), 131.8 (M <sub>2</sub> ), 15.5 (M <sub>3</sub> ), 31.6 (M <sub>4</sub> ), 93.3 (M <sub>5</sub> ) <sup>b</sup>	Dorje <i>et al.</i> (1991b), Billard <i>et al.</i> (1995)
M <sub>1</sub> -toxins:	2.3 (M <sub>1</sub> ), 23 (M <sub>2</sub> ), 1.4 (M <sub>3</sub> ), 5.5 (M <sub>4</sub> ), 3.7 (M <sub>5</sub> ) <sup>b</sup>	Buckley <i>et al.</i> (1989), Dorje <i>et al.</i> (1991b), Billard <i>et al.</i> (1995)
MT7	107.2 (M <sub>1</sub> ), 10.0 (M <sub>2</sub> ), 93.3 (M <sub>3</sub> ), 11.0 (M <sub>4</sub> ), 489.8 (M <sub>5</sub> ) <sup>b</sup>	Buckley <i>et al.</i> (1989), Dorje <i>et al.</i> (1991b)
MT1	49.2 (M <sub>1</sub> ), 4.4 (M <sub>2</sub> ), 29.6 (M <sub>3</sub> ), 5.5 (M <sub>4</sub> ) <sup>b</sup>	Jerusalinsky <i>et al.</i> (2000), Karlsson <i>et al.</i> (2000)
MT2	16 (M <sub>1</sub> ), 3.6 (M <sub>2</sub> ), 118 (M <sub>3</sub> ), 57 (M <sub>5</sub> ) <sup>b</sup>	Jerusalinsky <i>et al.</i> (2000), Karlsson <i>et al.</i> (2000)
MT4	50.1 (M <sub>1</sub> ), 13.2 (M <sub>2</sub> ), 213.8 (M <sub>3</sub> ), 31.6 (M <sub>4</sub> ), 134.9 (M <sub>5</sub> ) <sup>b</sup>	Jerusalinsky <i>et al.</i> (2000), Karlsson <i>et al.</i> (2000)
MT5	0.1 (M <sub>1</sub> ), >2000 (M <sub>2</sub> ), >2000 (M <sub>3</sub> ), >2000 (M <sub>4</sub> ), >2000 (M <sub>5</sub> ) <sup>b</sup>	Jerusalinsky <i>et al.</i> (2000), Karlsson <i>et al.</i> (2000)
M <sub>4</sub> -toxins:	22–49 (M <sub>1</sub> ), >1000 (M <sub>2</sub> ), >1000 (M <sub>3</sub> ), 29–58 (M <sub>4</sub> ), >1000 (M <sub>5</sub> ) <sup>b</sup>	Jerusalinsky <i>et al.</i> (2000), Karlsson <i>et al.</i> (2000)
MT3	630 (M <sub>1</sub> ), >2000 (M <sub>2</sub> ), >2000 (M <sub>3</sub> ), 1900 (M <sub>4</sub> ), >2000 (M <sub>5</sub> ) <sup>b</sup>	Jerusalinsky <i>et al.</i> (2000), Karlsson <i>et al.</i> (2000)
MT $\alpha$	62 (M <sub>1</sub> ), >1000 (M <sub>2</sub> ), >1000 (M <sub>3</sub> ), 87 (M <sub>4</sub> ), >1000 (M <sub>5</sub> ) <sup>b</sup>	Jerusalinsky <i>et al.</i> (2000), Karlsson <i>et al.</i> (2000)
MT $\beta$	180 (M <sub>1</sub> ), >1000 (M <sub>2</sub> ), >1000 (M <sub>3</sub> ), 540 (M <sub>4</sub> ), >1000 (M <sub>5</sub> ) <sup>b</sup>	Jerusalinsky <i>et al.</i> (2000), Karlsson <i>et al.</i> (2000)
Oxybutinin	78–1100 (M <sub>1</sub> ), >1000 (M <sub>2</sub> ), >1000 (M <sub>3</sub> ), 1.4–2 (M <sub>4</sub> ), >1000 (M <sub>5</sub> ) <sup>b</sup>	Moriya <i>et al.</i> (1999)
Pirenzepine	190 (M <sub>1</sub> ), >425 (M <sub>2</sub> ), >425 (M <sub>3</sub> ), 3.6 (M <sub>4</sub> ), >425 (M <sub>5</sub> ) <sup>b</sup>	Buckley <i>et al.</i> (1989), Dorje <i>et al.</i> (1991b), Billard <i>et al.</i> (1995), Kukkonen <i>et al.</i> (1996), Moriya <i>et al.</i> (1999)
Scopolamine	23 (M <sub>1</sub> ), 44 (M <sub>2</sub> ), 3 (M <sub>3</sub> ), 5 (M <sub>4</sub> ), 8 (M <sub>5</sub> ) <sup>b</sup>	Billard <i>et al.</i> (1995)
Silahexacyclium	>1000 (M <sub>1</sub> ), >2000 (M <sub>2</sub> ), 140 (M <sub>3</sub> ), 120 (M <sub>4</sub> ), 350 (M <sub>5</sub> ) <sup>b</sup>	Buckley <i>et al.</i> (1989)
Tiquizium	0.66 (M <sub>1</sub> ), 13 (M <sub>2</sub> ), 0.72 (M <sub>3</sub> ), 0.54 (M <sub>4</sub> ), 7.4 (M <sub>5</sub> ) <sup>a</sup>	Moriya <i>et al.</i> (1999)
[R]-Trihexyphenidyl	16 (M <sub>1</sub> ), 906 (M <sub>2</sub> ), 180 (M <sub>3</sub> ) <sup>b</sup>	Buckley <i>et al.</i> (1989), Dorje <i>et al.</i> (1991b), Billard <i>et al.</i> (1995), Kukkonen <i>et al.</i> (1996), Moriya <i>et al.</i> (1999)
Tripitramine	6.3 (M <sub>1</sub> ), 223.9 (M <sub>2</sub> ), 138.0 (M <sub>3</sub> ), 37.2 (M <sub>4</sub> ), 89.1 (M <sub>5</sub> ) <sup>b</sup>	Billard <i>et al.</i> (1995)
	4.6 (M <sub>1</sub> ), 211.8 (M <sub>2</sub> ), 37.8 (M <sub>3</sub> ), 21.1 (M <sub>4</sub> ) <sup>b</sup>	Buckley <i>et al.</i> (1989)
	11.4 (M <sub>1</sub> ), 373 (M <sub>3</sub> ), 69.3 (M <sub>5</sub> ) <sup>a</sup>	Moriya <i>et al.</i> (1999)
	7.1 (M <sub>1</sub> ), 303 (M <sub>2</sub> ), 75 (M <sub>3</sub> ), 17 (M <sub>4</sub> ), 66 (M <sub>5</sub> ) <sup>a</sup>	Billard <i>et al.</i> (1995)
	0.085 (M <sub>1</sub> ), 0.88 (M <sub>2</sub> ), 0.063 (M <sub>3</sub> ), 0.1 (M <sub>4</sub> ) <sup>b</sup>	Buckley <i>et al.</i> (1989)
	2.0 (M <sub>1</sub> ), 35 (M <sub>2</sub> ), 1.2 (M <sub>3</sub> ), 3.2 (M <sub>4</sub> ), 2.0 (M <sub>5</sub> ) <sup>b</sup>	Buckley <i>et al.</i> (1989)
	4.1 (M <sub>1</sub> ), 4.0 (M <sub>2</sub> ), 2.8 (M <sub>3</sub> ), 3.6 (M <sub>4</sub> ), 8.2 (M <sub>5</sub> ) <sup>a</sup>	Moriya <i>et al.</i> (1999)
	0.37 (M <sub>1</sub> ), 7.08 (M <sub>2</sub> ), 2.45 (M <sub>3</sub> ), 0.83 (M <sub>4</sub> ), 5.01 (M <sub>5</sub> ) <sup>b</sup>	Dorje <i>et al.</i> (1991b)
	1.6 (M <sub>1</sub> ), 0.3 (M <sub>2</sub> ), 38 (M <sub>3</sub> ), 6 (M <sub>4</sub> ), 3.4 (M <sub>5</sub> ) <sup>b</sup>	Maggio <i>et al.</i> (1994)
<b>nAChR agonist</b>		
Anabaseine	58 (Rat $\alpha$ 7)	Kem <i>et al.</i> (1997)
Carbachol	4130 (Bovine $\alpha$ 3 $\beta$ 4) <sup>c</sup>	Free <i>et al.</i> (2003)
Cytisine	517 (Bovine $\alpha$ 3 $\beta$ 4) <sup>c</sup>	Free <i>et al.</i> (2003)
1,1-Dimethyl-4-phenylpiperazinium	469 (Bovine $\alpha$ 3 $\beta$ 4) <sup>c</sup>	Free <i>et al.</i> (2003)
(–)-Epibatidine	230 (Rat $\alpha$ 7)	Gerzanich <i>et al.</i> (1995), Bunnelle <i>et al.</i> (2004)
(+)-Epibatidine	0.15 (Human $\alpha$ 3 $\beta$ 2) <sup>d</sup> , 0.031 (Human $\alpha$ 3) <sup>e</sup> , 3.1 (Human $\alpha$ 7) <sup>e</sup>	Gerzanich <i>et al.</i> (1995)
( $\pm$ )-Epibatidine	0.23 (Human $\alpha$ 3 $\beta$ 2) <sup>d</sup> , 0.00059 (Human $\alpha$ 3) <sup>e</sup> , 9.8 (Human $\alpha$ 7) <sup>e</sup>	Gerzanich <i>et al.</i> (1995)
	0.3 (Bovine $\alpha$ 3 $\beta$ 4) <sup>c</sup>	Davies <i>et al.</i> (1999), Free <i>et al.</i> (2003)
	233.6 (Rat $\alpha$ 7)	Davies <i>et al.</i> (1999)
Nicotine	400–14 000 (Rat $\alpha$ 7)	Kem <i>et al.</i> (1997), Davies <i>et al.</i> (1999), Free <i>et al.</i> (2003), Bunnelle <i>et al.</i> (2004)
RJR-2403	517 (Bovine $\alpha$ 3 $\beta$ 4) <sup>c</sup>	Free <i>et al.</i> (2003), Bunnelle <i>et al.</i> (2004)
	36 000 (Rat $\alpha$ 7)	Bunnelle <i>et al.</i> (2004)
<b>nAChR antagonist</b>		
$\alpha$ -Bungarotoxin	0.7 (Rat $\alpha$ 7)	Davies <i>et al.</i> (1999)
Methyllycaconitine	1.15 ( $\alpha$ 7) <sup>f</sup>	Alkondon <i>et al.</i> (1992), Maggi <i>et al.</i> (1999), Davies <i>et al.</i> (1999), Free <i>et al.</i> (2003)
	1.1–4.3 (Rat $\alpha$ 7)	(1999), Davies <i>et al.</i> (1999), Free <i>et al.</i> (2003)
	420 (Bovine $\alpha$ 3 $\beta$ 4) <sup>c</sup>	Maggi <i>et al.</i> (1999)
MG 624 (4-oxystilbene derivative)	106 ( $\alpha$ 7) <sup>f</sup>	Maggi <i>et al.</i> (1999)
D-Tubocurarine	1570 ( $\alpha$ 7) <sup>f</sup>	Maggi <i>et al.</i> (1999), Free <i>et al.</i> (2003)
	105 (Bovine $\alpha$ 3 $\beta$ 4) <sup>c</sup>	Maggi <i>et al.</i> (1999), Free <i>et al.</i> (2003)

<sup>a</sup>Stably transfected Sf9 insect cells.<sup>b</sup>Stably transfected CHO-K1 cells.<sup>c</sup>Stably expressed in human embryonic kidney (HEK) 293 cells.<sup>d</sup>Stably expressed in *Xenopus* oocytes.<sup>e</sup>Immuno-isolated from SH-SY5Y neuroblastoma cells.<sup>f</sup>Immuno-immobilized from chick optic lobe.

Note: When affinity values were reported as  $pK_i$ , the negative antilogarithm was calculated to determine  $K_i$  value; unless otherwise specified, affinity for  $\alpha$ 7 subunits is determined by displacement of <sup>3</sup>[H]- $\alpha$ -bungarotoxin binding.

**Table 5** Affinity profiles of mAChR agonists and antagonists in intestinal tissue

Drug	Tissue preparation	$K_i$ (nM)	References
<i>mAChR agonist</i>			
Bethanechol	Guinea-pig ileum – mucosal scrapings	53 000	Carey <i>et al.</i> (1987), Kuwahara <i>et al.</i> (1987b)
	Guinea-pig proximal colon – mucosal scrapings	53 000	
	Guinea-pig distal colon – mucosal scrapings	35 000	
Carbachol	Guinea-pig ileum – mucosal scrapings	8500	Carey <i>et al.</i> (1987), Kuwahara <i>et al.</i> (1987b)
	Guinea-pig proximal colon – mucosal scrapings	9800	
	Guinea-pig distal colon – mucosal scrapings	5500	
McN A343	Guinea-pig ileum – mucosal scrapings	180	Carey <i>et al.</i> (1987)
<i>mAChR Antagonist</i>			
AF-DX 116	Canine ileum – purified synaptosomal fraction from deep muscular nerve plexus	6200	Chandan <i>et al.</i> (1991a, b), Kostka <i>et al.</i> (1992), O'Malley <i>et al.</i> (1995)
	Pig jejunum – mucosa-submucosa	300	
	Rat colon – mucosa-submucosa	2189	
Atropine	Pig jejunum – mucosa-submucosa	0.4	Chandan <i>et al.</i> (1991b), O'Malley <i>et al.</i> (1995)
	Rat colon – mucosa-submucosa	0.87	
4-DAMP	Canine ileum – purified synaptosomal fraction from deep muscular nerve plexus	39	Carey <i>et al.</i> (1987), Kuwahara <i>et al.</i> (1987b), Chandan <i>et al.</i> (1991a, b), Kostka <i>et al.</i> (1992), O'Malley <i>et al.</i> (1995)
	Guinea-pig ileum – mucosal scrapings	1.8	
	Pig jejunum – mucosa-submucosa	2.5	
	Rat colon – mucosa-submucosa	5.2	
	Guinea-pig proximal colon – mucosal scrapings	3.0	
	Guinea-pig distal colon – mucosal scrapings	2.2	
Methoctramine	Canine ileum – purified synaptosomal fraction from deep muscular nerve plexus	2250	Kostka <i>et al.</i> (1992)
Pirenzepine	Canine ileum – purified synaptosomal fraction from deep muscular nerve plexus	2540	Carey <i>et al.</i> (1987), Kuwahara <i>et al.</i> (1987b), Chandan <i>et al.</i> (1991a, b), Kostka <i>et al.</i> (1992), O'Malley <i>et al.</i> (1995)
	Guinea-pig ileum – mucosal scrapings	35	
	Guinea-pig proximal colon – mucosal scrapings	100	
	Guinea-pig distal colon – mucosal scrapings	170	
	Porcine jejunum – mucosa-submucosa	87.5	
	Rat colon – mucosa-submucosa	155.0	

Note: When affinity values were reported as  $pK_i$ , the negative antilogarithm was calculated to determine  $K_i$  value.

gut regions, and on the balance of the data it seems that ACh plays a minor role. Perplexingly, however, there is little consensus on the role of specific AChRs, with studies suggesting involvement of mAChRs but not nAChRs, nAChRs but not mAChRs, both mAChRs and nAChRs, or neither receptor type. Much of this variation is attributed to species and regional differences, although tissue preparation and environmental variability may also play a role. Additionally, some of the vagaries in the field could be reconciled by a consideration of the expression profiles of specific mAChR and nAChR subtypes and the location of these receptors (i.e. on stimulatory versus inhibitory neurons).

#### Stimulated ion transport

The majority of studies of cholinergic regulation of ion transport have focused on stimulated ion transport, either through electrical field stimulation (EFS – causes release of ACh and other neurotransmitters) or through application of a cholinergic compound to tissues in Ussing chambers. Thus, it has long been known that ACh and cholinergic agonists stimulate fluid and  $\text{Cl}^-$  secretion in the mammalian (including human) gut (Tidball, 1961; Hubel, 1976; Isaacs *et al.*, 1976). It is also well established that the addition of carbachol (CCh) or BCh to muscle-stripped intestine (small

or large bowel) results in a rapid onset, but transient ( $\sim 10$ – $15$  min duration), increase in  $I_{\text{SC}}$  that is due mainly to lumenally directed  $\text{Cl}^-$  efflux across the epithelium (Cooke, 1984; Chandan *et al.*, 1991b; Chough *et al.*, 1993; Strabel and Diener, 1995). Additionally, cholinergic stimulation promotes  $\text{HCO}_3^-$  secretion and may inhibit  $\text{Na}^+$  absorption in some tissues (Browning *et al.*, 1978; Chandan *et al.*, 1991c; Geibel *et al.*, 2000).

However, species- and tissue-specific differences are commonplace when considering: (1) the contribution of cholinergic nerves to the transient (1–5 min duration) increase in  $I_{\text{SC}}$  evoked by EFS, (2) the contribution of neurons to  $I_{\text{SC}}$  responses evoked by CCh or BCh and (3) involvement of mAChR and nAChR in cholinergic control of increases in  $I_{\text{SC}}$ . For example, CCh-induced  $\Delta I_{\text{SC}}$  in guinea-pig ileum is TTX insensitive (Cooke, 1984), whereas colonic responses to CCh are reduced by TTX (Kuwahara *et al.*, 1987b). In porcine proximal, but not distal jejunum, TTX pretreatment actually augments the increase in  $I_{\text{SC}}$  evoked by low concentrations of CCh (0.1–3  $\mu\text{M}$ ) (Chandan *et al.*, 1991a, b). Also, CCh- and BCh-evoked  $\Delta I_{\text{SC}}$  in the rat small intestine are TTX insensitive (Przyborski and Levin, 1997), whereas, in the rat colon,  $I_{\text{SC}}$  responses to several AChR agonists, including ACh and CCh, are reduced by TTX (O'Malley *et al.*, 1995). Along with the species and regional differences in TTX sensitivity to cholinergically mediated ion transport, there is further

evidence that should caution against making broad conclusions based on individual studies: Prior *et al.* (2004) showed that colonic tissue from two lines of the Flinders strain of rats have different TTX sensitivities to CCh-induced increases in  $I_{SC}$ .

Although the relative contribution of nerves to the  $\Delta I_{SC}$  evoked by CCh or BCh can be debated, there is little doubt that EFS elicits increases in  $I_{SC}$  that are due in large part to ACh release. Thus, EFS-induced  $\Delta I_{SC}$  are typically reduced by ~50% in the presence of ATR (Cooke *et al.*, 1983a, b; Cooke, 1984; Kuwahara *et al.*, 1987a, b; Hildebrand and Brown, 1990; Chandan *et al.*, 1991a, b; Javed and Cooke, 1992). Some investigators, based on the use of HEX, have implicated a small role for nAChR in the EFS response in whole thickness tissue (Hildebrand and Brown, 1990; Chandan *et al.*, 1991a, b). Thus, the majority of reports indicate that changes in epithelial ion transport as a consequence of ACh release (mimicked *in vitro* by EFS or application of exogenous cholinomimetics) are via mAChRs and pharmacological analyses do, in general, support the dogma that this is via epithelial  $M_3$  and neuronal  $M_1$  mAChRs (Cooke *et al.*, 1983a; Cooke, 1984; Carey *et al.*, 1987; Kuwahara *et al.*, 1987a, b; Diener *et al.*, 1989; Traynor *et al.*, 1991; Chandan *et al.*, 1991a, b; Javed and Cooke, 1992; O'Malley *et al.*, 1995; Przyborski and Levin, 1997; Townsend *et al.*, 2005). Stimulation of nAChRs does affect intestinal  $I_{SC}$ , typically in full-thickness tissue (i.e. with an intact myenteric plexus), but the magnitude of the  $\Delta I_{SC}$  is significantly smaller than that evoked by CCh or BCh (Zimmerman and Binder, 1983; Diener *et al.*, 1989; Hildebrand and Brown, 1990; Chandan *et al.*, 1991a, b; O'Malley *et al.*, 1995; Sayer *et al.*, 2002). This does not trivialize the importance of nAChR input to cholinergic control of epithelial ion transport, rather it highlights the fact that high concentrations of CCh, with its mixed mAChR and nAChR effects, are unlikely to reveal nAChR effects because these are over-run by the effects of mAChR ligation (Tapper *et al.*, 1978; Sayer *et al.*, 2002).

Surprisingly, cholinergically mediated ion transport is poorly understood in the mouse. In full-thickness jejunal tissue from suckling and adult mice (it is extremely difficult to strip away the outer muscle layers from the mouse gut),  $I_{SC}$  responses to EFS are partially mediated by mAChRs and CCh-induced  $\Delta I_{SC}$  are TTX insensitive (Carey and Cooke, 1989; Sheldon *et al.*, 1989). However,  $I_{SC}$  responses following application of the  $Na^+$  channel activator veratridine, which stimulates enteric nerves pharmacologically, rather than electrically, do not involve muscarinic receptors (Sheldon *et al.*, 1990). Dimethylphenylpiperazinium (DMPP) (i.e. nAChR agonist)-induced increases in  $I_{SC}$  in the jejunum are, in accordance with other species, neuronally driven (Sheldon *et al.*, 1989). CCh- and BCh-evoked increases in  $I_{SC}$  in the mouse colon are mediated in part by nerves (Sagmanligil and Levin, 1993; Carew and Thorn, 2000), although subsequent studies failed to confirm this (Sayer *et al.*, 2002). The latter study found that HEX did not significantly affect  $\Delta I_{SC}$  evoked by CCh, but that nicotine evoked a drop in  $I_{SC}$  that was inhibited by TTX pretreatment. Furthermore, as a striking addition to the field, mice lacking  $M_3$  mAChRs produce  $I_{SC}$  responses to CCh

or BCh of normal magnitudes, with  $M_1$  mAChRs implicated as the compensating mechanism for the lack of the  $M_3$  receptor subtype (Haberberger *et al.*, 2006; Hirota and McKay, 2006).

There is a dearth of information regarding cholinergic regulation of ion transport in the human intestine. In muscle-stripped segments of left colon, 25–50% of the  $\Delta I_{SC}$  evoked by EFS is due to cholinergic input (Hubel *et al.*, 1987; Kuwahara *et al.*, 1989) and responses to CCh are completely abolished by ATR (Kuwahara *et al.*, 1989).

Clearly, the lack of data obtained from human tissue needs to be addressed, as does a comparison of the applicability of findings from mouse tissue, particularly as the mouse is the species of choice to model human intestinal disease. Additionally, whereas cholinergic control of enteric epithelial ion transport is, under normal circumstances, dominated by  $M_3$  and  $M_1$  mAChRs (lack of involvement of  $M_2$  and  $M_4$  mAChR subtypes is generally inferred from pharmacological data, but has never been directly proven, and  $M_5$  mAChR involvement has not been addressed), the modulating effect of nAChRs should be better characterized, as should cholinergic neuronal interactions within the submucosa and between the submucosal and myenteric plexuses. Finally, in segments of rabbit small intestine containing Peyer's patches, CCh evoked a decrease rather than an increase in  $I_{SC}$  (Brayden and Baird, 1994) and greater involvement of nAChR has been implicated in colonic tissue from young compared to mature guinea-pigs (Powell and Reddix, 2000); thus, whereas the majority of our understanding of the control of enteric epithelial ion transport has been gleaned from analyses of tissues from adult animals, there is value in considering tissue from infants/young animals and from those with an enhanced complement of immune cells (see below).

### Intracellular epithelial effects of cholinergic agonists: influence on ion transport

Assessment of rat intestine has demonstrated that ACh-driven epithelial  $Cl^-$  secretion is  $Ca^{2+}$  dependent (Hardcastle *et al.*, 1984), activating a basolateral  $K^+$  efflux from the enterocyte, which is required for the subsequent increase in  $I_{SC}$  (Hardcastle and Hardcastle, 1986). Whole-cell patch-clamp recordings from rat and human colonic epithelial cells showed that ACh (and CCh) act through mAChRs to evoke membrane hyperpolarization, an effect that is dependent on the presence of  $Ca^{2+}$  (Yada and Okada, 1984; Yada *et al.*, 1989; Devor *et al.*, 1990; Bohme *et al.*, 1991). This hyperpolarization is attributed to  $K^+$  efflux from the basolateral cell membrane, which, in the human T84 colonic epithelial cell line, occurs independently of cAMP-stimulated  $K^+$  efflux, indicating a separate  $Ca^{2+}$ -activated  $K^+$  channel in these cells (McRoberts *et al.*, 1985; Dharmasathaporn and Pandol, 1986) (Figure 1). Furthermore, microelectrode recordings in the human colon-derived HT-29 epithelial cell line show that CCh-stimulated  $K^+$  efflux immediately follows, but is not dependent on, epithelial cell depolarization, a phenomenon attributed to  $Cl^-$  efflux from both apical and basolateral membranes (Bajjnath *et al.*,

1992a,b), although the functional significance of this finding is unclear. CCh-induced increases in  $I_{SC}$  have consistently been associated with serosal-to-mucosal movement of  $Cl^-$  across epithelial cell monolayers (Dharmasathaporn and Pandol, 1986), and most, but not all, of the studies to date favour a CCh-driven apical  $Cl^-$  conductance in T84 cells (frequently used as a model of secretory epithelia) (Dharmasathaporn and Pandol, 1986; Cliff and Frizzell, 1990; Devor *et al.*, 1990; Venglarik *et al.*, 1990).

cAMP-dependent secretagogues (e.g. VIP,  $PGE_2$  and forskolin) increase apical  $Cl^-$  conductance via the cystic fibrosis transmembrane conductance regulator (CFTR) (Mandel *et al.*, 1986) and potentiate the  $I_{SC}$  response to CCh in human colonic epithelial cell lines and freshly isolated human colonic tissue (Dharmasathaporn and Pandol, 1986; Mall *et al.*, 1998). The  $Cl^-$  conductances evoked by cAMP versus  $Ca^{2+}$  are not identical, thus suggesting the existence of two distinct  $Cl^-$  channels in human intestinal epithelium (Cliff and Frizzell, 1990; Vaandrager *et al.*, 1991; Bajnath *et al.*, 1992a), a postulate supported by molecular analyses (Mohammad-Panah *et al.*, 2001; Evans *et al.*, 2004). Collectively, these studies indicate that activation of basolateral  $M_3$  mAChRs raises intracellular  $Ca^{2+}$ , resulting in  $Ca^{2+}$ -dependent basolateral  $K^+$  efflux, which creates the driving force for flux of  $Cl^-$  into the gut lumen, observed in the Ussing chambers as an increase in  $I_{SC}$  (Kachintorn *et al.*, 1993b) (Figure 1).

In human colonic epithelial cell monolayers, CCh stimulation induces turnover of membrane phospholipids (Kopp *et al.*, 1989; Dickinson *et al.*, 1992). Indeed, it has been elegantly demonstrated that inositol 3,4,5,6-tetrakisphosphate ( $IP_4$ ) generation, subsequent to  $IP_3$  production, contributes to the transient nature of the epithelial response to CCh, serving to turn off  $Cl^-$  secretion (Kachintorn *et al.*, 1993a; Vajanaphanich *et al.*, 1994). PKC appears to have a similar role in limiting the  $Cl^-$  secretory actions of CCh (Cohn, 1990; Kachintorn *et al.*, 1992), although there is also evidence that at least one PKC isoform,  $PKC\alpha$ , contributes initially to the stimulation of  $Cl^-$  secretion, while acting to inhibit this response in the longer run, possibly through inhibition of the basolateral  $Ca^{2+}$ -activated  $K^+$  channel (Bajnath *et al.*, 1992b; van den Berghe *et al.*, 1992) (Figure 2). Analyses with the T84 cell line suggest that phosphorylation of the MAP kinases, extracellular signal-regulated kinase and p38, constitute additional 'off' signals for CCh-stimulated epithelial chloride secretion (Keely *et al.*, 1998; Keely and Barrett, 2003). This occurs via transactivation of the epidermal growth factor receptor (EGFR) and requires release of transforming growth factor- $\alpha$  (TGF- $\alpha$ ), elevations in intracellular  $Ca^{2+}$ , activation of calmodulin, and activation and association of Src kinase and PYK-2 with the EGFR (Uribe *et al.*, 1996a; Keely *et al.*, 2000; McCole *et al.*, 2002). Interestingly, phospholipid production has also been linked to epidermal growth factor (EGF)-induced inhibition of  $Cl^-$  secretion (Uribe *et al.*, 1996b). However, the phospholipid-generating effects of EGF are dependent on phosphatidylinositol 3-kinase, whereas those of CCh are not, demonstrating that mobilization of distinct intracellular signalling pathways can culminate in a similar physiological end point.

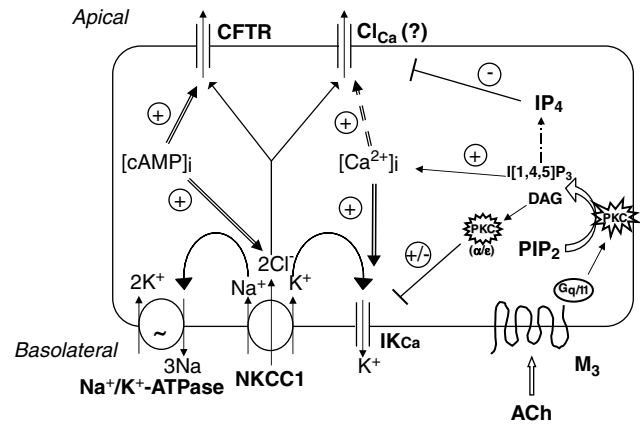

**Figure 2** Intracellular regulation of intestinal epithelial  $Cl^-$  secretion by ACh (based on the secretory pathway depicted in Figure 1).  $G_{q/11}$   $\alpha$  subunits (coupled to odd-numbered mAChRs) stimulate membrane phospholipid turnover by PLC. Inositol 1,4,5-trisphosphate ( $[1,4,5]P_3$ ) stimulates a rise in  $[Ca^{2+}]_i$ ; eventual conversion of  $IP_3$  products to  $IP_4$  by phosphatidylinositol kinases turns off  $Cl^-$  secretion, possibly by inhibiting  $Ca^{2+}$ -activated  $Cl^-$  channels ( $Cl_{Ca}$ ). DAG activates classical (e.g.  $PKC\alpha$ ) and novel (e.g.  $PKC\epsilon$ ) isoforms of PKC;  $PKC\alpha$  and/or  $PKC\epsilon$  may be required for initial stimulation of apical  $Cl^-$  secretion, but ultimately serve to downregulate this process through effects on ion transport molecules. Refer to the text for further details.

### Cholinergic–non-cholinergic interactions: influence on ion transport

ACh does not exist in isolation and so it is not surprising that other signalling molecules from nerves, stromal or immune cells influence cholinergic regulation of epithelial ion transport. The opportunities for such interaction are immense given the diversity of biogenic amines, neuropeptides and neurotransmitters that exist in the gut (at least 25 in the enteric nervous system alone; McConalogue and Furness, 1994). As examples: in the guinea-pig small intestine, noradrenaline inhibits the secretory responses to cholinergic nerve stimulation and somatostatin inhibits  $\Delta I_{SC}$  evoked by CCh and DMPP (Keast *et al.*, 1986); opioid analogues can inhibit tonic ACh release from the rabbit ileal SMP (Hautefeuille *et al.*, 1985); neuropeptide Y and the structurally related peptide YY reduce baseline  $I_{SC}$  and diminish BCh-induced  $\Delta I_{SC}$  in mouse jejunum (Riviere *et al.*, 1993; Nakanishi *et al.*, 1996; McKay *et al.*, 1996a); increases in  $I_{SC}$  evoked by substance P (SP) in guinea-pig jejunum are reduced in the presence of ATR, implying SP-induced release of ACh as a significant part of the  $Cl^-$  secretory response (Perdue *et al.*, 1987; Goldhill and Angel, 1998). Products of arachidonic acid metabolism also influence cholinergic responses. Thus, the prosecretory effects of leukotrienes in the guinea-pig colon are partially dependent on the activity of mAChRs (Hammerbeck and Brown, 1993),  $PGD_2$  antagonizes the effects of BCh and CCh on canine proximal colon (Rangachari and Betti, 1993), and blockade of PG synthesis with indomethacin reduces the  $I_{SC}$  response evoked by CCh by 70% in human descending colon (Mall *et al.*, 1998).

The observation that other neurotransmitters modulate the cholinergic control of enteric epithelial ion transport is

intuitive, especially considering that most cholinergic nerves also synthesize and release other neurotransmitters/neuropeptides. Indeed, the implications of this cotransmission, occurring in the context of endogenous eicosanoids and cytokines (see below), for modulation of the cholinergic control of epithelial ion transport is immense, not to mention the effects of the temporal and stoichiometric relationship between the release of multiple mediators. Clearly, many outstanding issues remain: Do specific neurotransmitters simply oppose/antagonize the effect of ACh, and if so, how (e.g. activation of inhibitory neurons)? Are other neurotransmitters influencing the release of ACh under normal or pathophysiological conditions? Are specific neurotransmitters influencing expression or activity of ACh receptors or of subsequent intracellular signalling cascades? The answers to these questions will significantly enhance our understanding of the complexities of the cross-talk between the cholinergic system and other mediators in the control of enteric ion transport in health and disease.

### Alterations to cholinergically mediated intestinal ion transport during pathology

Intestinal infection and inflammation profoundly effect water balance in the gut, leading to either secretory or malabsorptive diarrhoea or to constipation. However, and seemingly paradoxically, gut dysfunction is often characterized by a general hyporesponsiveness to prosecretory agents, including diminution of  $\Delta I_{SC}$  evocable by cholinomimetics. Thus, tissue from diabetic rats (Perdue and Davison, 1988), rats exposed to 10 Gy radiation (Francois *et al.*, 1998), rats infected with nematode parasites (Masson *et al.*, 1996; Venkova and Greenwood-van Meerveld, 2006), mice with T-cell-driven enteropathies (McKay *et al.*, 1999; Radojevic *et al.*, 1999), aganglionic colon from children with Hirschsprung's disease (Hardy *et al.*, 1993) and tissues from virtually every animal model of colitis (Goldhill *et al.*, 1993; Kachur *et al.*, 1995; Asfaha *et al.*, 1999; Diaz-Granados *et al.*, 2000; Miceli *et al.*, 2002; Sanchez de Medina *et al.*, 2002; Perez-Navarro *et al.*, 2005a, b) display reduced  $I_{SC}$  responses to cholinomimetics. In some instances, such as pathologies accompanied by severe ulceration, such hyporesponsiveness, could simply reflect a lack of intact epithelium, although this is not an adequate explanation for most intestinal pathologies. Indeed, there is significant evidence implicating several specific mechanisms in the cholinergic hyporesponsiveness associated with intestinal infection and inflammation. In some instances, this involves altered ACh metabolism; for example, increased AChE expression and activity have been noted in the jejunal epithelium of rats infected with *Nippostrongylus brasiliensis* (Russell *et al.*, 2000) and in aganglionic segments of rectosigmoid colon from children with Hirschsprung's disease (characterized by a lack of development of cholinergic enteric nerves in the hindgut) (Hardy *et al.*, 1993). Tri-nitrobenzene sulphonic acid (TNBS)-induced colonic inflammation and infection with *Trichinella spiralis* both affect ACh metabolism in smooth muscle preparations as well, where decreased packaging and exocytosis of ACh from the myenteric plexus is observed (Main

*et al.*, 1993; Davis *et al.*, 1998; Poli *et al.*, 2001). In contrast, others have found either no change or an increase in intestinal ChAT expression (Palmer and Koch, 1995; Green *et al.*, 2004), whereas increased levels of non-neuronal ACh have been reported in other (non-intestinal) inflammatory diseases (Wessler *et al.*, 2003). It is possible that this hyporesponsiveness represents a means to limit ongoing  $Cl^-$  secretion during disease, but the full significance of these data is not clear. Moreover, should some commonality be identified in the mechanism responsible for the epithelial hyporesponsiveness to cholinomimetics; this could represent a significant advance in the development of therapies to regulate enteric water balance.

We have reported that  $I_{SC}$  responses to CCh in colonic tissue from mice with dextran sodium-sulphate (DSS)-induced colitis are not only attenuated, but reversed in direction (Sayer *et al.*, 2002). The CCh-induced decrease in  $I_{SC}$  was abolished by pretreatment with TTX or inhibitors of inducible nitric oxide (NO) synthase and partially reversed by pretreatment with HEX; overall, the findings were compatible with a novel means of controlling epithelial ion transport via activation of neuronal nAChRs in the myenteric plexus leading to NO liberation from glial cells (Green *et al.*, 2004). Although NO release can explain the CCh-induced drop in  $I_{SC}$ , it does not account for the lack of a CCh-induced increase in  $I_{SC}$  in colonic tissue from DSS-treated mice. We speculate that this deficiency is due to loss of mAChRs or inflammation-induced changes in epithelial  $Ca^{2+}$ -dependent secretory pathways, although proinflammatory cytokines such as interferon- $\gamma$  (IFN- $\gamma$ ) and tumour necrosis factor- $\alpha$  (TNF- $\alpha$ ) may actually increase expression of AChRs (Poea-Guyon *et al.*, 2005) (see below).

The issue of direct regulation of cholinergic effects by cytokines has been taken up *in vitro* using CCh treatment of human colon-derived epithelial monolayers. Exposure to activated immune cells or recombinant IFN- $\gamma$  results in diminished responses to CCh (Holmgren *et al.*, 1989; Madara and Stafford, 1989; McKay *et al.*, 1996b; Madsen *et al.*, 1997; McKay and Singh, 1997) that have been linked to reduced expression of the  $Na^+/K^+-ATPase$  pump and the  $Na^+/K^+/2Cl^-$  co-transporter (Sugi *et al.*, 2001; Bertelsen *et al.*, 2004), whereas TNF- $\alpha$  treatment appears to enhance the effect of CCh (Oprins *et al.*, 2000, 2002). Treatment of colonic epithelial cells with IFN- $\gamma$  leads to an increased production of TGF- $\alpha$ , which, through activation of the EGFR, as mentioned earlier, has been shown to inhibit  $Ca^{2+}$ -dependent  $Cl^-$  secretion (Uribe *et al.*, 1996a, 2002). These studies only hint at the full influence inflammatory mediators undoubtedly have on cholinergically mediated epithelial ion transport; the potential of other cytokines to alter cholinergic responses remains to be defined, and the number of cytokines/growth factors that occur constitutively or sporadically in the gut translates into a daunting myriad of possibilities. This area is especially fascinating in light of the reverse relationship, that is, the ability of the cholinergic pathway to alter cytokine responses. This relationship is designated as the cholinergic anti-inflammatory pathway, through which stimulation of the vagus nerve suppresses endotoxin-induced release of inflammatory mediators, in-

cluding TNF- $\alpha$ , from immune cells, an effect that is mediated by  $\alpha 7$  nAChRs (Pavlov *et al.*, 2003; Wang *et al.*, 2003).

*In vitro* infection with the bacterial pathogen enterohemorrhagic *Escherichia coli* reduces CCh-induced secretory responses in T84 cell monolayers (Hecht and Koutsouris, 1999). Intriguingly, application of fatty acids has been postulated as another means of limiting CCh-induced Cl<sup>-</sup> secretion (Schultheiss *et al.*, 2001) and the gut commensal flora is the predominant source of fatty acids. Additionally, both viral and helminthic infections have been shown to reduce CCh-evoked  $\Delta I_{SC}$  (Argenzio *et al.*, 1996; Reardon *et al.*, 2001). Finally, and of major health concern, diarrhoea resulting from *Vibrio cholerae* infection is potentiated by cholinergically mediated secretory events (Banks *et al.*, 2004) that can be mobilized by serotonin release from enterochromaffin cells (Lundgren, 1998), which, in turn, at least in the duodenum, evokes ACh release (Tuo and Isenberg, 2003). Infections can have long-lasting effects on the host (e.g. post-infectious irritable bowel syndrome) (Farthing, 2005), and so awareness of any cholinergic contribution to the altered intestinal fluid status elicited by infections (Jodal *et al.*, 1993) can be of value in not only providing a means of symptom relief/disease management but also in the evaluation of disease aetiology. These isolated examples simply illustrate the general lack of data on the impact of one of the major endogenous homeostatic control systems (i.e. the cholinergic system) on the duration of infection (and *vice versa*) and the physiological perturbations that they evoke.

## Conclusion

ACh is an important regulator of the electrogenic ion fluxes that govern directional water movements in the intestine. Identification of ACh receptor subtypes involved in this process has not always been straightforward and this is partially attributable to a lack of pharmacological agonists and antagonists with high specificity for receptor subtypes. For the most part, however, it is generally accepted that cholinergic control of intestinal ion transport is accomplished predominantly via activation of M<sub>1</sub> and M<sub>3</sub> AChR on neurons and enterocytes, respectively. These fundamental pharmacological data can now be confirmed or refuted and supplemented by a molecular knockout strategy that has already been applied to the mouse and has revealed some intriguing and unexpected data (Wess, 2004; Haberberger *et al.*, 2006; Hirota and McKay, 2006). Also, data from human and mouse tissue is noticeably scant; a particular concern in the context of modelling and treating human disease. Moreover, it is clear that infection and inflammation result in an altered enteric cholinergic system, a generalized hyporesponsiveness of the epithelium to cholinergic stimulation and unmasking of regulatory pathways that are either not operational, or go undetected, when tissues from healthy individuals are assessed. Furthermore, there is intriguing, but fragmented, data on how disease can uncouple mAChRs from intracellular signalling cascades and we have only a rudimentary knowledge of how other neuroimmune (and stromal)-derived factors influence the overall activity of cholinergic signalling in the gut and produce changes in

active epithelial ion transport. The cholinergic system is a principal player in enteric homeostasis, and we suggest that the outstanding challenges in this field lie in unraveling the communication within the neuronal circuitry and the role of specific AChRs therein, in defining the mechanism(s) by which immune responses (i.e. disease) modulate the cholinergic system, and in assessing cholinergic signalling in the setting of a dynamic tissue in which other signalling molecules are released, either tonically or sporadically.

## Acknowledgements

We are grateful for the helpful comments provided by Drs Denis Crankshaw and Mary Perdue, McMaster University. Studies from the authors' laboratory were funded by grants from the Crohn's and Colitis Foundation of Canada and the Canadian Institutes of Health and Research (#MT-13421). D McKay is recipient of a Canada Research Chair (Tier 1) in Intestinal Immunophysiology in Health and Disease and C Hirota holds an Ontario Graduate Studentship.

## Conflict of Interests

The authors state no conflict of interests.

## References

- Alkondon M, Pereira EF, Wonnacott S, Albuquerque EX (1992). Blockade of nicotinic currents in hippocampal neurons defines methyllycaconitine as a potent and specific receptor antagonist. *Mol Pharmacol* **41**: 802–808.
- Anini Y, Brubaker PL (2003). Muscarinic receptors control glucagon-like peptide 1 secretion by human endocrine L cells. *Endocrinology* **144**: 3244–3250.
- Anini Y, Hansotia T, Brubaker PL (2002). Muscarinic receptors control postprandial release of glucagon-like peptide-1: *in vivo* and *in vitro* studies in rats. *Endocrinology* **143**: 2420–2426.
- Argenzio RA, Armstrong M, Rhoads JM (1996). Role of the enteric nervous system in piglet cryptosporidiosis. *J Pharmacol Exp Ther* **279**: 1109–1115.
- Asfaha S, Bell CJ, Wallace JL, MacNaughton WK (1999). Prolonged colonic epithelial hyporesponsiveness after colitis: role of inducible nitric oxide synthase. *Am J Physiol* **276**: G703–G710.
- Bajnath RB, Dekker K, Vaandrager AB, de Jonge HR, Groot JA (1992a). Biphasic increase of apical Cl<sup>-</sup> conductance by muscarinic stimulation of HT-29cl.19A human colon carcinoma cell line: evidence for activation of different Cl<sup>-</sup> conductances by carbachol and forskolin. *J Membr Biol* **127**: 81–94.
- Bajnath RB, van Hoeve MH, de Jonge HR, Groot JA (1992b). Regulation of apical Cl<sup>-</sup> conductance and basolateral K<sup>+</sup> conductances by phorbol esters in HT-29cl.19A cells. *Am J Physiol* **263**: C759–C766.
- Banks MR, Golder M, Farthing MJ, Burleigh DE (2004). Intracellular potentiation between two second messenger systems may contribute to cholera toxin induced intestinal secretion in humans. *Gut* **53**: 50–57.
- Barrett KE, Keely SJ (2000). Chloride secretion by the intestinal epithelium: molecular basis and regulatory aspects. *Annu Rev Physiol* **62**: 535–572.
- Battaglioli E, Gotti C, Terzano S, Flora A, Clementi F, Fornasari D (1998). Expression and transcriptional regulation of the human  $\alpha 3$  neuronal nicotinic receptor subunit in T lymphocyte cell lines. *J Neurochem* **71**: 1261–1270.

- Bertelsen LS, Eckmann L, Barrett KE (2004). Prolonged interferon-gamma exposure decreases ion transport, NKCC1, and Na<sup>+</sup>-K<sup>+</sup>-ATPase expression in human intestinal xenografts *in vivo*. *Am J Physiol* **286**: G157–G165.
- Biagi B, Wang YZ, Cooke HJ (1990). Effects of tetrodotoxin on chloride secretion in rabbit distal colon: tissue and cellular studies. *Am J Physiol* **258**: G223–G230.
- Billard W, Binch 3rd H, Crosby G, McQuade RD (1995). Identification of the primary muscarinic autoreceptor subtype in rat striatum as m2 through a correlation of *in vivo* microdialysis and *in vitro* receptor binding data. *J Pharmacol Exp Ther* **273**: 273–279.
- Bohme M, Diener M, Rummel W (1991). Calcium- and cyclic-AMP-mediated secretory responses in isolated colonic crypts. *Pflugers Arch* **419**: 144–151.
- Bornstein JC, Costa M, Grider JR (2004). Enteric motor and interneuronal circuits controlling motility. *Neurogastroenterol Motil* **16** (Suppl 1): 34–38.
- Brayden DJ, Baird AW (1994). A distinctive electrophysiological signature of the Peyer's patches of rabbit intestine. *Br J Pharmacol* **113**: 593–599.
- Brookes SJ (2001). Classes of enteric nerve cells in the guinea-pig small intestine. *Anat Rec* **262**: 58–70.
- Brown DR, Timmermans JP (2004). Lessons from the porcine enteric nervous system. *Neurogastroenterol Motil* **16** (Suppl 1): 50–54.
- Browning JG, Hardcastle J, Hardcastle PT, Redfern JS (1978). Localization of the effect of acetylcholine in regulating intestinal ion transport. *J Physiol* **281**: 15–27.
- Buckley NJ, Bonner TI, Buckley CM, Brann MR (1989). Antagonist binding properties of five cloned muscarinic receptors expressed in CHO-K1 cells. *Mol Pharmacol* **35**: 469–476.
- Bunnelle WH, Dart MJ, Schrimpf MR (2004). Design of ligands for the nicotinic acetylcholine receptors: the quest for selectivity. *Curr Top Med Chem* **4**: 299–334.
- Carew MA, Thorn P (2000). Carbachol-stimulated chloride secretion in mouse colon: evidence of a role for autocrine prostaglandin E<sub>2</sub> release. *Exp Physiol* **85**: 67–72.
- Carey HV, Cooke HJ (1989). Neuromodulation of intestinal transport in the suckling mouse. *Am J Physiol* **256**: R481–R486.
- Carey HV, Tien XY, Wallace LJ, Cooke HJ (1987). Muscarinic receptor subtypes mediating the mucosal response to neural stimulation of guinea pig ileum. *Am J Physiol* **253**: G323–G329.
- Caulfield MP (1993). Muscarinic receptors – characterization, coupling and function. *Pharmacol Ther* **58**: 319–379.
- Caulfield MP, Birdsall NJ (1998). International Union of Pharmacology. XVII. Classification of muscarinic acetylcholine receptors. *Pharmacol Rev* **50**: 279–290.
- Chandan R, Hildebrand KR, Seybold VS, Soldani G, Brown DR (1991a). Cholinergic neurons and muscarinic receptors regulate anion secretion in pig distal jejunum. *Eur J Pharmacol* **193**: 265–273.
- Chandan R, Megarry BH, O'Grady SM, Seybold VS, Brown DR (1991b). Muscarinic cholinergic regulation of electrogenic chloride secretion in porcine proximal jejunum. *J Pharmacol Exp Ther* **257**: 908–917.
- Chandan R, O'Grady SM, Brown DR (1991c). Modulation of Na<sup>+</sup>, Cl<sup>-</sup> and HCO<sub>3</sub><sup>-</sup> transport by carbachol in pig distal jejunum. *Eur J Pharmacol* **193**: 257–264.
- Chough SP, Goldenring JR, Hurst RD, Ballantyne GH, Modlin IM (1993). Calcium modulation of the effects of serotonin, carbachol, and histamine on rabbit ileal ion transport. *Yale J Biol Med* **66**: 525–540.
- Cliff WH, Frizzell RA (1990). Separate Cl<sup>-</sup> conductances activated by cAMP and Ca<sup>2+</sup> in Cl<sup>-</sup>-secreting epithelial cells. *Proc Natl Acad Sci USA* **87**: 4956–4960.
- Cohn JA (1990). Protein kinase C mediates cholinergically regulated protein phosphorylation in a Cl<sup>-</sup>-secreting epithelium. *Am J Physiol* **258**: C227–C233.
- Cooke HJ (1984). Influence of enteric cholinergic neurons on mucosal transport in guinea pig ileum. *Am J Physiol* **246**: G263–G267.
- Cooke HJ, Shonnard K, Highison G, Wood JD (1983a). Effects of neurotransmitter release on mucosal transport in guinea pig ileum. *Am J Physiol* **245**: G745–G750.
- Cooke HJ, Shonnard K, Wood JD (1983b). Effects of neuronal stimulation on mucosal transport in guinea pig ileum. *Am J Physiol* **245**: G290–G296.
- Costa M, Brookes SJ, Hennig GW (2000). Anatomy and physiology of the enteric nervous system. *Gut* **47** (Suppl 4): iv15–iv19.
- Craven PA, Derubertis FR (1983). Patterns of prostaglandin synthesis and degradation in isolated superficial and proliferative colonic epithelial cells compared to residual colon. *Prostaglandins* **26**: 583–604.
- Davies AR, Hardick DJ, Blagbrough IS, Potter BV, Wolstenholme AJ, Wonnacott S (1999). Characterisation of the binding of methyllycaconitine: a new radioligand for labelling α7-type neuronal nicotinic acetylcholine receptors. *Neuropharmacology* **38**: 679–690.
- Davis KA, Masella J, Blennerhassett MG (1998). Acetylcholine metabolism in the inflamed rat intestine. *Exp Neurol* **152**: 251–258.
- Devor DC, Simasko SM, Duffey ME (1990). Carbachol induces oscillations of membrane potassium conductance in a colonic cell line, T84. *Am J Physiol* **258**: C318–C326.
- Dharmasathaphorn K, Pandol SJ (1986). Mechanism of chloride secretion induced by carbachol in a colonic epithelial cell line. *J Clin Invest* **77**: 348–354.
- Diaz-Granados N, Howe K, Lu J, McKay DM (2000). Dextran sulfate sodium-induced colonic histopathology, but not altered epithelial ion transport, is reduced by inhibition of phosphodiesterase activity. *Am J Pathol* **156**: 2169–2177.
- Dickinson KE, Frizzell RA, Sekar MC (1992). Activation of T84 cell chloride channels by carbachol involves a phosphoinositide-coupled muscarinic M<sub>3</sub> receptor. *Eur J Pharmacol* **225**: 291–298.
- Diener M, Knobloch SF, Bridges RJ, Keilmann T, Rummel W (1989). Cholinergic-mediated secretion in the rat colon: neuronal and epithelial muscarinic responses. *Eur J Pharmacol* **168**: 219–229.
- Dorje F, Levey AI, Brann MR (1991a). Immunological detection of muscarinic receptor subtype proteins (m1–m5) in rabbit peripheral tissues. *Mol Pharmacol* **40**: 459–462.
- Dorje F, Wess J, Lambrecht G, Tacke R, Mutschler E, Brann MR (1991b). Antagonist binding profiles of five cloned human muscarinic receptor subtypes. *J Pharmacol Exp Ther* **256**: 727–733.
- Eckenstein F, Thoenen H (1982). Production of specific antisera and monoclonal antibodies to choline acetyltransferase: characterization and use for identification of cholinergic neurons. *EMBO J* **1**: 363–368.
- Eglen RM (2005). Muscarinic receptor subtype pharmacology and physiology. *Prog Med Chem* **43**: 105–136.
- Eglen RM, Hegde SS, Watson N (1996). Muscarinic receptor subtypes and smooth muscle function. *Pharmacol Rev* **48**: 531–565.
- Eiden LE (1998). The cholinergic gene locus. *J Neurochem* **70**: 2227–2240.
- Evans SR, Thoreson WB, Beck CL (2004). Molecular and functional analyses of two new calcium-activated chloride channel family members from mouse eye and intestine. *J Biol Chem* **279**: 41792–41800.
- Farthing MJ (2005). Functional diarrhea. *Curr Gastroenterol Rep* **7**: 350–357.
- Field M (1974). Intestinal secretion. *Gastroenterology* **66**: 1063–1084.
- Fonnum F (1975). A rapid radiochemical method for the determination of choline acetyltransferase. *J Neurochem* **24**: 407–409.
- Francois A, Aigueperse J, Gourmelon P, MacNaughton WK, Griffiths NM (1998). Exposure to ionizing radiation modifies neurally-evoked electrolyte transport and some inflammatory responses in rat colon *in vitro*. *Int J Radiat Biol* **73**: 93–101.
- Free RB, von Fischer ND, Boyd RT, McKay DB (2003). Pharmacological characterization of recombinant bovine α3β4 neuronal nicotinic receptors stably expressed in HEK 293 cells. *Neurosci Lett* **343**: 180–184.
- Furness JB (2000). Types of neurons in the enteric nervous system. *J Auton Nerv Syst* **81**: 87–96.
- Furness JB, Jones C, Nurgali K, Clerc N (2004). Intrinsic primary afferent neurons and nerve circuits within the intestine. *Prog Neurobiol* **72**: 143–164.
- Furuichi A, Makimoto N, Ogishima M, Nakao K, Tsukamoto M, Kanematsu T *et al.* (2001). *In vivo* assessment of the regulatory mechanism of cholinergic neuronal activity associated with motility in dog small intestine. *Jpn J Pharmacol* **86**: 73–78.

- Geibel JP, Singh S, Rajendran VM, Binder HJ (2000). HCO<sub>3</sub><sup>-</sup> secretion in the rat colonic crypt is closely linked to Cl<sup>-</sup> secretion. *Gastroenterology* **118**: 101–107.
- Gerzanich V, Peng X, Wang F, Wells G, Anand R, Fletcher S *et al.* (1995). Comparative pharmacology of epibatidine: a potent agonist for neuronal nicotinic acetylcholine receptors. *Mol Pharmacol* **48**: 774–782.
- Glushakov AV, Voytenko LP, Skok MV, Skok V (2004). Distribution of neuronal nicotinic acetylcholine receptors containing different alpha-subunits in the submucosal plexus of the guinea-pig. *Auton Neurosci* **110**: 19–26.
- Goldhill J, Angel I (1998). Mechanism of tachykinin NK<sub>3</sub> receptor-mediated colonic ion transport in the guinea pig. *Eur J Pharmacol* **363**: 161–168.
- Goldhill JM, Burakoff R, Donovan V, Rose K, Percy WH (1993). Defective modulation of colonic secretomotor neurons in a rabbit model of colitis. *Am J Physiol* **264**: G671–G677.
- Gotti C, Clementi F (2004). Neuronal nicotinic receptors: from structure to pathology. *Prog Neurobiol* **74**: 363–396.
- Grando SA, Kawashima K, Wessler I (2003). Introduction: the non-neuronal cholinergic system in humans. *Life Sci* **72**: 2009–2012.
- Green CL, Ho W, Sharkey KA, McKay DM (2004). Dextran sodium sulfate-induced colitis reveals nicotinic modulation of ion transport via iNOS-derived NO. *Am J Physiol* **287**: G706–G714.
- Haberberger R, Schultheiss G, Diener M (2006). Epithelial muscarinic M<sub>1</sub> receptors contribute to carbachol-induced ion secretion in mouse colon. *Eur J Pharmacol* **530**: 229–233.
- Hammerbeck DM, Brown DR (1993). Neurally mediated actions of leukotrienes on ion transport in guinea pig distal colon. *J Pharmacol Exp Ther* **264**: 384–390.
- Hardcastle J, Hardcastle PT (1986). The involvement of basolateral potassium channels in the intestinal response to secretagogues in the rat. *J Physiol* **379**: 331–345.
- Hardcastle J, Hardcastle PT, Noble JM (1984). The involvement of calcium in the intestinal response to secretagogues in the rat. *J Physiol* **355**: 465–478.
- Hardy SP, Smith PM, Bayston R, Spitz L (1993). Electrogenic colonic ion transport in Hirschsprung's disease: reduced secretion to the neural secretagogues acetylcholine and iloprost. *Gut* **34**: 1405–1411.
- Harrington AM, Hutson JM, Southwell BR (2005). Immunohistochemical localization of substance P NK1 receptor in guinea pig distal colon. *Neurogastroenterol Motil* **17**: 727–737.
- Hautefeuille M, Brantl V, Dumontier AM, Desjeux JF (1985). Effect of a beta-casomorphin analog on ion transport in rabbit ileum: evidence for a cholinergic mediation. *Regul Pept Suppl* **4**: 219–220.
- Hebb CO (1954). Acetylcholine metabolism of nervous tissue. *Pharmacol Rev* **6**: 39–43.
- Hebb CO, Whittaker VP (1958). Intracellular distributions of acetylcholine and choline acetylase. *J Physiol* **142**: 187–196.
- Hecht G, Koutsouris A (1999). Enteropathogenic *E. coli* attenuates secretagogue-induced net intestinal ion transport but not Cl<sup>-</sup> secretion. *Am J Physiol* **276**: G781–G788.
- Hens J, Schrodler F, Brehmer A, Adriaensen D, Neuhuber W, Scheuermann DW *et al.* (2000). Mucosal projections of enteric neurons in the porcine small intestine. *J Comp Neurol* **421**: 429–436.
- Hiemke C, Stolp M, Reuss S, Wevers A, Reinhardt S, Maelicke A *et al.* (1996). Expression of alpha subunit genes of nicotinic acetylcholine receptors in human lymphocytes. *Neurosci Lett* **214**: 171–174.
- Hildebrand KR, Brown DR (1990). Intrinsic neuroregulation of ion transport in porcine distal jejunum. *J Pharmacol Exp Ther* **255**: 285–292.
- Hirota C, McKay DM (2006). M<sub>3</sub> muscarinic receptor-deficient mice retain bethanechol-mediated intestinal ion transport and are more sensitive to colitis. *Can J Physiol Pharmacol* (in press).
- Hogg RC, Raggenbass M, Bertrand D (2003). Nicotinic acetylcholine receptors: from structure to brain function. *Rev Physiol Biochem Pharmacol* **147**: 1–46.
- Holmgren J, Fryklund J, Larsson H (1989). Gamma-interferon-mediated down-regulation of electrolyte secretion by intestinal epithelial cells: a local immune mechanism? *Scand J Immunol* **30**: 499–503.
- Hubel KA (1976). Intestinal ion transport: effect of norepinephrine, pilocarpine, and atropine. *Am J Physiol* **231**: 252–257.
- Hubel KA, Renquist K, Shirazi S (1987). Ion transport in human cecum, transverse colon, and sigmoid colon *in vitro*. Baseline and response to electrical stimulation of intrinsic nerves. *Gastroenterology* **92**: 501–507.
- Hulme EC, Birdsall NJ, Buckley NJ (1990). Muscarinic receptor subtypes. *Annu Rev Pharmacol Toxicol* **30**: 633–673.
- Isaacs PE, Corbett CL, Riley AK, Hawker PC, Turnberg LA (1976). *In vitro* behavior of human intestinal mucosa. The influence of acetylcholine on ion transport. *J Clin Invest* **58**: 535–542.
- Javed NH, Cooke HJ (1992). Acetylcholine release from colonic submucosal neurons associated with chloride secretion in the guinea pig. *Am J Physiol* **262**: G131–G136.
- Jerusalinsky D, Kornisiuk E, Alfaro P, Quillfeldt J, Ferreira A, Rial VE *et al.* (2000). Muscarinic toxins: novel pharmacological tools for the muscarinic cholinergic system. *Toxicol* **38**: 747–761.
- Jodal M, Wingren U, Jansson M, Heidemann M, Lundgren O (1993). Nerve involvement in fluid transport in the inflamed rat jejunum. *Gut* **34**: 1526–1530.
- Kachintorn U, Vajanaphanich M, Barrett KE, Traynor-Kaplan AE (1993a). Elevation of inositol tetrakisphosphate parallels inhibition of Ca<sup>2+</sup>-dependent Cl<sup>-</sup> secretion in T84 cells. *Am J Physiol* **264**: C671–C676.
- Kachintorn U, Vajanaphanich M, Traynor-Kaplan AE, Dharmasathaporn K, Barrett KE (1993b). Activation by calcium alone of chloride secretion in T84 epithelial cells. *Br J Pharmacol* **109**: 510–517.
- Kachintorn U, Vongkovit P, Vajanaphanich M, Dinh S, Barrett KE, Dharmasathaporn K (1992). Dual effects of a phorbol ester on calcium-dependent chloride secretion by T84 epithelial cells. *Am J Physiol* **262**: C15–C22.
- Kachur JF, Keshavarzian A, Sundaresan R, Doria M, Walsh R, de las Alas MM *et al.* (1995). Colitis reduces short-circuit current response to inflammatory mediators in rat colonic mucosa. *Inflammation* **19**: 245–259.
- Karlsson E, Jolkkonen M, Mulugeta E, Onali P, Adem A (2000). Snake toxins with high selectivity for subtypes of muscarinic acetylcholine receptors. *Biochimie* **82**: 793–806.
- Kawashima K, Fujii T (2000). Extraneuronal cholinergic system in lymphocytes. *Pharmacol Ther* **86**: 29–48.
- Keast JR, Furness JB, Costa M (1985). Investigations of nerve populations influencing ion transport that can be stimulated electrically, by serotonin and by a nicotinic agonist. *Naunyn Schmiedeberg's Arch Pharmacol* **331**: 260–266.
- Keast JR, Furness JB, Costa M (1986). Effects of noradrenaline and somatostatin on basal and stimulated mucosal ion transport in the guinea-pig small intestine. *Naunyn Schmiedeberg's Arch Pharmacol* **333**: 393–399.
- Keely SJ, Barrett KE (2000). Regulation of chloride secretion. Novel pathways and messengers. *Ann NY Acad Sci* **915**: 67–76.
- Keely SJ, Barrett KE (2003). p38 mitogen-activated protein kinase inhibits calcium-dependent chloride secretion in T84 colonic epithelial cells. *Am J Physiol* **284**: C339–C348.
- Keely SJ, Calandrella SO, Barrett KE (2000). Carbachol-stimulated transactivation of epidermal growth factor receptor and mitogen-activated protein kinase in T84 cells is mediated by intracellular Ca<sup>2+</sup>, PYK-2, and p60<sup>src</sup>. *J Biol Chem* **275**: 12619–12625.
- Keely SJ, Uribe JM, Barrett KE (1998). Carbachol stimulates transactivation of epidermal growth factor receptor and mitogen-activated protein kinase in T84 cells. Implications for carbachol-stimulated chloride secretion. *J Biol Chem* **271**: 27111–27117.
- Kem WR, Mahnir VM, Papke RL, Lingle CJ (1997). Anabaseine is a potent agonist on muscle and neuronal alpha-bungarotoxin-sensitive nicotinic receptors. *J Pharmacol Exp Ther* **283**: 979–992.
- King LS, Kozono D, Agre P (2004). From structure to disease: the evolving tale of aquaporin biology. *Nat Rev Mol Cell Biol* **5**: 687–698.
- Kirchgesner AL, Liu MT (1998). Immunohistochemical localization of nicotinic acetylcholine receptors in the guinea pig bowel and pancreas. *J Comp Neurol* **390**: 497–514.
- Kopp R, Lambrecht G, Mutschler E, Moser U, Tacke R, Pfeiffer A (1989). Human HT-29 colon carcinoma cells contain muscarinic

- M<sub>3</sub> receptors coupled to phosphoinositide metabolism. *Eur J Pharmacol* 172: 397–405.
- Kostka P, Ahmad S, Kwan CY, Daniel EE, Gordon RK, Chiang PK (1992). Prejunctional muscarinic receptors in the deep muscular plexus of canine ileum: comparison with smooth muscle receptors. *J Pharmacol Exp Ther* 263: 226–231.
- Kukkonen JP, Nasman J, Ojala P, Oker-Blom C, Akerman KE (1996). Functional properties of muscarinic receptor subtypes Hm1, Hm3 and Hm5 expressed in Sf9 cells using the baculovirus expression system. *J Pharmacol Exp Ther* 279: 593–601.
- Kulkarni-Narla A, Beitz AJ, Brown DR (1999). Catecholaminergic, cholinergic and peptidergic innervation of gut-associated lymphoid tissue in porcine jejunum and ileum. *Cell Tissue Res* 298: 275–286.
- Kuwahara A, Bowen S, Wang J, Condon C, Cooke HJ (1987a). Epithelial responses evoked by stimulation of submucosal neurons in guinea pig distal colon. *Am J Physiol* 252: G667–G674.
- Kuwahara A, Cooke HJ, Carey HV, Mekhjian H, Ellison EC, McGregor B (1989). Effects of enteric neural stimulation on chloride transport in human left colon *in vitro*. *Dig Dis Sci* 34: 206–213.
- Kuwahara A, Tien XY, Wallace LJ, Cooke HJ (1987b). Cholinergic receptors mediating secretion in guinea pig colon. *J Pharmacol Exp Ther* 242: 600–606.
- Laforenza U, Cova E, Gastaldi G, Tritto S, Grazioli M, LaRusso NF *et al.* (2005a). Aquaporin-8 is involved in water transport in isolated superficial colonocytes from rat proximal colon. *J Nutr* 135: 2329–2336.
- Laforenza U, Gastaldi G, Grazioli M, Cova E, Tritto S, Faelli A *et al.* (2005b). Expression and immunolocalization of aquaporin-7 in rat gastrointestinal tract. *Biol Cell* 97: 605–613.
- Lanzafame AA, Christopoulos A, Mitchelson F (2003). Cellular signaling mechanisms for muscarinic acetylcholine receptors. *Receptors Channels* 9: 241–260.
- Levey AI (1993). Immunological localization of m1-m5 muscarinic acetylcholine receptors in peripheral tissues and brain. *Life Sci* 52: 441–448.
- Li B, Stribley JA, Ticu A, Xie W, Schopfer LM, Hammond P *et al.* (2000). Abundant tissue butyrylcholinesterase and its possible function in the acetylcholinesterase knockout mouse. *J Neurochem* 75: 1320–1331.
- Lindqvist S, Hernon J, Sharp P, Johns N, Addison S, Watson M *et al.* (2002). The colon-selective spasmolytic otilonium bromide inhibits muscarinic M<sub>3</sub> receptor-coupled calcium signals in isolated human colonic crypts. *Br J Pharmacol* 137: 1134–1142.
- Loo DD, Wright EM, Zeuthen T (2002). Water pumps. *J Physiol* 542: 53–60.
- Lundgren O (1998). 5-Hydroxytryptamine, enterotoxins, and intestinal fluid secretion. *Gastroenterology* 115: 1009–1012.
- Macallan DR, Lunt GG, Wonnacott S, Swanson KL, Rapoport H, Albuquerque EX (1988). Methyllycaconitine and (+)-anatoxin-a differentiate between nicotinic receptors in vertebrate and invertebrate nervous systems. *FEBS Lett* 226: 357–363.
- Madara JL, Stafford J (1989). Interferon-gamma directly affects barrier function of cultured intestinal epithelial monolayers. *J Clin Invest* 83: 724–727.
- Madsen KL, Lewis SA, Tavernini MM, Hibbard J, Fedorak RN (1997). Interleukin 10 prevents cytokine-induced disruption of T84 monolayer barrier integrity and limits chloride secretion. *Gastroenterology* 113: 151–159.
- Maeda A, Kubo T, Mishina M, Numa S (1988). Tissue distribution of mRNAs encoding muscarinic acetylcholine receptor subtypes. *FEBS Lett* 239: 339–342.
- Maggi L, Palma E, Eusebi F, Moretti M, Balestra B, Clementi F *et al.* (1999). Selective effects of a 4-oxystilbene derivative on wild and mutant neuronal chick  $\alpha 7$  nicotinic receptor. *Br J Pharmacol* 126: 285–295.
- Maggio R, Barbier P, Bolognesi ML, Minarini A, Tedeschi D, Melchiorre C (1994). Binding profile of the selective muscarinic receptor antagonist triptamine. *Eur J Pharmacol* 268: 459–462.
- Main C, Blennerhassett P, Collins SM (1993). Human recombinant interleukin 1 beta suppresses acetylcholine release from rat myenteric plexus. *Gastroenterology* 104: 1648–1654.
- Mall M, Bleich M, Schurlein M, Kuhr J, Seydewitz HH, Brandis M *et al.* (1998). Cholinergic ion secretion in human colon requires coactivation by cAMP. *Am J Physiol* 275: G1274–G1281.
- Mandel KG, Dharmasathaphorn K, McRoberts JA (1986). Characterization of a cyclic AMP-activated Cl<sup>-</sup> transport pathway in the apical membrane of a human colonic epithelial cell line. *J Biol Chem* 261: 704–712.
- Masson SD, McKay DM, Stead RH, Agro A, Stanisz A, Perdue MH (1996). *Nippostrongylus brasiliensis* infection evokes neuronal abnormalities and alterations in neurally regulated electrolyte transport in rat jejunum. *Parasitol* 113 (Part 2): 173–182.
- Massoulié J, Sussman J, Bon S, Silman I (1993). Structure and functions of acetylcholinesterase and butyrylcholinesterase. *Prog Brain Res* 98: 139–146.
- Masyuk AI, Marinelli RA, Larusso NF (2002). Water transport by epithelia of the digestive tract. *Gastroenterology* 122: 545–562.
- Matsuzaki T, Tajika Y, Ablimit A, Aoki T, Hagiwara H, Takata K (2004). Aquaporins in the digestive system. *Med Electron Microsc* 37: 71–80.
- McCole DE, Keely SJ, Coffey RJ, Barrett KE (2002). Transactivation of the epidermal growth factor receptor in colonic epithelial cells by carbachol requires extracellular release of transforming growth factor- $\alpha$ . *J Biol Chem* 277: 42603–42612.
- McConalogue K, Furness JB (1994). Gastrointestinal neurotransmitters. *Baillieres Clin Endocrinol Metab* 8: 51–76.
- McKay DM, Berin MC, Fondacaro JD, Perdue MH (1996a). Effects of neuropeptide Y and substance P on antigen-induced ion secretion in rat jejunum. *Am J Physiol* 271: G987–G992.
- McKay DM, Croitoru K, Perdue MH (1996b). T cell-monocyte interactions regulate epithelial physiology in a coculture model of inflammation. *Am J Physiol* 270: C418–C428.
- McKay DM, Lu J, Jedrzkiewicz S, Ho W, Sharkey KA (1999). Nitric oxide participates in the recovery of normal jejunal epithelial ion transport following exposure to the superantigen, *Staphylococcus aureus* enterotoxin B. *J Immunol* 163: 4519–4526.
- McKay DM, Singh PK (1997). Superantigen activation of immune cells evokes epithelial (T84) transport and barrier abnormalities via IFN- $\gamma$  and TNF $\alpha$ : inhibition of increased permeability, but not diminished secretory responses by TGF- $\beta$ 2. *J Immunol* 159: 2382–2390.
- McMurray G, Shaw C, Johnston CF, Halton DW (1993). Choline acetyltransferase (ChAT) immunoreactivity in a sub-population of mammalian intestinal endocrine cells. *Comp Biochem Physiol C* 106: 509–515.
- McRoberts JA, Beuerlein G, Dharmasathaphorn K (1985). Cyclic AMP and Ca<sup>2+</sup>-activated K<sup>+</sup> transport in a human colonic epithelial cell line. *J Biol Chem* 260: 14163–14172.
- Miceli P, Morris GP, MacNaughton WK, Vanner S (2002). Alterations in capsaicin-evoked electrolyte transport during the evolution of guinea pig TNBS ileitis. *Am J Physiol* 282: G972–G980.
- Mobasheri A, Shakibaei M, Marples D (2004). Immunohistochemical localization of aquaporin 10 in the apical membranes of the human ileum: a potential pathway for luminal water and small solute absorption. *Histochem Cell Biol* 121: 463–471.
- Mohammad-Panah R, Gyomory K, Rommens J, Choudhury M, Li C, Wang Y *et al.* (2001). CIC-2 contributes to native chloride secretion by a human intestinal cell line, Caco-2. *J Biol Chem* 276: 8306–8313.
- Moriya H, Takagi Y, Nakanishi T, Hayashi M, Tani T, Hirotsu I (1999). Affinity profiles of various muscarinic antagonists for cloned human muscarinic acetylcholine receptor (mAChR) subtypes and mAChRs in rat heart and submandibular gland. *Life Sci* 64: 2351–2358.
- Nakanishi T, Kanayama S, Kiyohara T, Okuno M, Shinomura Y, Matsuzawa Y (1996). Peptide YY-induced alteration of colonic electrolyte transport in the rat. *Regul Pept* 61: 149–154.
- Neunlist M, Reiche D, Michel K, Pfannkuche H, Hoppe S, Schemann M (1999). The enteric nervous system: region and target specific projections and neurochemical codes. *Eur J Morphol* 37: 233–240.
- Nicke A, Wonnacott S, Lewis RJ (2004). Alpha-conotoxins as tools for the elucidation of structure and function of neuronal nicotinic acetylcholine receptor subtypes. *Eur J Biochem* 271: 2305–2319.
- Obaid AL, Koyano T, Lindstrom J, Sakai T, Salzberg BM (1999). Spatiotemporal patterns of activity in an intact mammalian

- network with single-cell resolution: optical studies of nicotinic activity in an enteric plexus. *J Neurosci* **19**: 3073–3093.
- O'Malley KE, Farrell CB, O'Boyle KM, Baird AW (1995). Cholinergic activation of Cl<sup>-</sup> secretion in rat colonic epithelia. *Eur J Pharmacol* **275**: 83–89.
- Oprins JC, Meijer HP, Groot JA (2000). TNF-alpha potentiates the ion secretion induced by muscarinic receptor activation in HT29cl.19A cells. *Am J Physiol* **278**: C463–C472.
- Oprins JC, van der Burg C, Meijer HP, Munnik T, Groot JA (2002). Tumour necrosis factor alpha potentiates ion secretion induced by histamine in a human intestinal epithelial cell line and in mouse colon: involvement of the phospholipase D pathway. *Gut* **50**: 314–321.
- Oue T, Yoneda A, Shima H, Puri P (2000). Muscarinic acetylcholine receptor expression in aganglionic bowel. *Pediatr Surg Int* **16**: 267–271.
- Oyachi N, Lakshmanan J, Ahanya SN, Bassiri D, Atkinson JB, Ross MG (2003). Development of ovine fetal ileal motility: role of muscarinic receptor subtypes. *Am J Obstet Gynecol* **189**: 953–957.
- Palmer JM, Koch TR (1995). Altered neuropeptide content and cholinergic enzymatic activity in the inflamed guinea pig jejunum during parasitism. *Neuropeptides* **28**: 287–297.
- Pavlov VA, Wang H, Czura CJ, Friedman SG, Tracey KJ (2003). The cholinergic anti-inflammatory pathway: a missing link in neuroimmunomodulation. *Mol Med* **9**: 125–134.
- Perdue MH, Davison JS (1988). Altered regulation of intestinal ion transport by enteric nerves in diabetic rats. *Am J Physiol* **254**: G444–G449.
- Perdue MH, Galbraith R, Davison JS (1987). Evidence for substance P as a functional neurotransmitter in guinea pig small intestinal mucosa. *Regul Pept* **18**: 63–74.
- Perez-Navarro R, Ballester I, Zarzuelo A, Sanchez de Medina F (2005a). Disturbances in epithelial ionic secretion in different experimental models of colitis. *Life Sci* **76**: 1489–1501.
- Perez-Navarro R, Martinez-Augustin O, Ballester I, Zarzuelo A, Sanchez de Medina F (2005b). Experimental inflammation of the rat distal colon inhibits ion secretion in the proximal colon by affecting the enteric nervous system. *Naunyn Schmiedebergs Arch Pharmacol* **371**: 114–121.
- Poea-Guyon S, Christadoss P, Le Panse R, Guyon T, De Baets M, Wakkach A *et al.* (2005). Effects of cytokines on acetylcholine receptor expression: implications for myasthenia gravis. *J Immunol* **174**: 5941–5949.
- Poli E, Lazzaretti M, Grandi D, Pozzoli C, Coruzzi G (2001). Morphological and functional alterations of the myenteric plexus in rats with TNBS-induced colitis. *Neurochem Res* **26**: 1085–1093.
- Porter AJ, Wattoo DA, Brookes SJ, Costa M (2002). Cholinergic and nitrenergic interneurons in the myenteric plexus of the human colon. *Gut* **51**: 70–75.
- Porter AJ, Wattoo DA, Brookes SJ, Schemann M, Costa M (1996). Choline acetyltransferase immunoreactivity in the human small and large intestine. *Gastroenterology* **111**: 401–408.
- Powell AR, Reddix RA (2000). Differential effects of maturation on nicotinic- and muscarinic receptor-induced ion secretion in guinea pig distal colon. *Proc Soc Exp Biol Med* **224**: 147–151.
- Prior T, Hernandez J, Tougas G, Rangachari PK (2004). Phenotypic differences in cholinergic responses of distal colonic epithelium. *Exp Physiol* **89**: 209–217.
- Przyborski SA, Levin RJ (1997). Cholinergic modulation of electrogenic ion transport in different regions of the rat small intestine. *J Pharm Pharmacol* **49**: 691–697.
- Radojevic N, McKay DM, Merger M, Vallance BA, Collins SM, Croitoru K (1999). Characterization of enteric functional changes evoked by *in vivo* anti-CD3T cell activation. *Am J Physiol* **276**: R715–R723.
- Rangachari PK, Betti PA (1993). Biological activity of metabolites of PGD<sub>2</sub> on canine proximal colon. *Am J Physiol* **264**: G886–G894.
- Rangachari PK, McWade D (1986). Epithelial and mucosal preparations of canine proximal colon in ussing chambers: comparison of responses. *Life Sci* **38**: 1641–1652.
- Reardon C, Sanchez A, Hogaboam CM, McKay DM (2001). Tapeworm infection reduces epithelial ion transport abnormalities in murine dextran sulfate sodium-induced colitis. *Infect Immun* **69**: 4417–4423.
- Richardson CE, Morgan JM, Jasani B, Green JT, Rhodes J, Williams GT *et al.* (2001). Megacystis-microcolon-intestinal hypoperistalsis syndrome and the absence of the  $\alpha 3$  nicotinic acetylcholine receptor subunit. *Gastroenterology* **121**: 350–357.
- Richardson CE, Morgan JM, Jasani B, Green JT, Rhodes J, Williams GT *et al.* (2003). Effect of smoking and transdermal nicotine on colonic nicotinic acetylcholine receptors in ulcerative colitis. *Q J Med* **96**: 57–65.
- Riviere PJ, Rao RK, Pascaud X, Junien JL, Porreca F (1993). Effects of neuropeptide Y, peptide YY and sigma ligands on ion transport in mouse jejunum. *J Pharmacol Exp Ther* **264**: 1268–1274.
- Russell WS, Henson SM, Hussein AS, Tippins JR, Selkirk ME (2000). *Nippostrongylus brasiliensis*: infection induces upregulation of acetylcholinesterase activity on rat intestinal epithelial cells. *Exp Parasitol* **96**: 222–230.
- Sagmanligil V, Levin RJ (1993). Electrogenic ion secretion in proximal, mid and distal colon from fed and starved mice. *Comp Biochem Physiol C* **106**: 449–456.
- Sanchez de Medina F, Perez R, Martinez-Augustin O, Gonzalez R, Lorente MD, Galvez J *et al.* (2002). Disturbances of colonic ion secretion in inflammation: role of the enteric nervous system and cAMP. *Pflugers Arch* **444**: 378–388.
- Sang Q, Young HM (1998). The identification and chemical coding of cholinergic neurons in the small and large intestine of the mouse. *Anat Rec* **251**: 185–199.
- Sato KZ, Fujii T, Watanabe Y, Yamada S, Ando T, Kazuko F *et al.* (1999). Diversity of mRNA expression for muscarinic acetylcholine receptor subtypes and neuronal nicotinic acetylcholine receptor subunits in human mononuclear leukocytes and leukemic cell lines. *Neurosci Lett* **266**: 17–20.
- Sayer B, Lu J, Green C, Soderholm JD, Akhtar M, McKay DM (2002). Dextran sodium sulphate-induced colitis perturbs muscarinic cholinergic control of colonic epithelial ion transport. *Br J Pharmacol* **135**: 1794–1800.
- Schemann M, Neunlist M (2004). The human enteric nervous system. *Neurogastroenterol Motil* **16** (Suppl 1): 55–59.
- Schneider J, Jehle EC, Starlinger MJ, Neunlist M, Michel K, Hoppe S *et al.* (2001). Neurotransmitter coding of enteric neurones in the submucous plexus is changed in non-inflamed rectum of patients with Crohn's disease. *Neurogastroenterol Motil* **13**: 255–264.
- Schultheiss G, Ribeiro R, Diener M (2001). Fatty acids inhibit anion secretion in rat colon: apical and basolateral action sites. *Pflugers Arch* **442**: 603–613.
- Shachar-Hill B, Hill AE (2002). Paracellular fluid transport by epithelia. *Int Rev Cytol* **215**: 319–350.
- Sharif NA, Williams GW, DeSantis LM (1995). Affinities of muscarinic drugs for [<sup>3</sup>H]N-Methylscopolamine (NMS) and [<sup>3</sup>H]Oxotremorine (OXO) binding to a mixture of M<sub>1</sub>-M<sub>4</sub> muscarinic receptors: use of NMS/OXO-M ratios to group compounds into potential agonist, partial agonist, and antagonist classes. *Neurochem Res* **20**: 669–674.
- Sharkey KA, Lomax AE, Bertrand PP, Furness JB (1998). Electrophysiology, shape, and chemistry of neurons that project from guinea pig colon to inferior mesenteric ganglia. *Gastroenterology* **115**: 909–918.
- Sheldon RJ, Malarchik ME, Burks TF, Porreca F (1990). Effects of nerve stimulation on ion transport in mouse jejunum: responses to Veratrum alkaloids. *J Pharmacol Exp Ther* **252**: 636–642.
- Sheldon RJ, Malarchik ME, Fox DA, Burks TF, Porreca F (1989). Pharmacological characterization of neural mechanisms regulating mucosal ion transport in mouse jejunum. *J Pharmacol Exp Ther* **249**: 572–582.
- Strabel D, Diener M (1995). Evidence against direct activation of chloride secretion by carbachol in the rat distal colon. *Eur J Pharmacol* **274**: 181–191.
- Sugi K, Musch MW, Field M, Chang EB (2001). Inhibition of Na<sup>+</sup>, K<sup>+</sup>-ATPase by interferon gamma down-regulates intestinal epithelial transport and barrier function. *Gastroenterology* **120**: 1393–1403.
- Summers AE, Whelan CJ, Parsons ME (2003). Nicotinic acetylcholine receptor subunits and receptor activity in the epithelial cell line HT29. *Life Sci* **72**: 2091–2094.
- Sun Y, Fihn BM, Jodal M, Sjoval H (2000). Effects of neural blocking agents on motor activity and secretion in the proximal and distal

- rat colon: evidence of marked segmental differences in nicotinic receptor activity. *Scand J Gastroenterol* 35: 380–388.
- Takeuchi T, Fujinami K, Goto H, Fujita A, Taketo MM, Manabe T *et al.* (2005). Roles of M<sub>2</sub> and M<sub>4</sub> muscarinic receptors in regulating acetylcholine release from myenteric neurons of mouse ileum. *J Neurophysiol* 93: 2841–2848.
- Tapper EJ, Powell DW, Morris SM (1978). Cholinergic-adrenergic interactions on intestinal ion transport. *Am J Physiol* 235: E402–E409.
- Tidball CS (1961). Active chloride transport during intestinal secretion. *Am J Physiol* 200: 309–312.
- Townsend 4th D, Casey MA, Brown DR (2005). Mediation of neurogenic ion transport by acetylcholine, prostanoids and 5-hydroxytryptamine in porcine ileum. *Eur J Pharmacol* 519: 285–289.
- Traynor TR, Brown DR, O'Grady SM (1991). Regulation of ion transport in porcine distal colon: effects of putative neurotransmitters. *Gastroenterology* 100: 703–710.
- Tuo BG, Isenberg JI (2003). Effect of 5-hydroxytryptamine on duodenal mucosal bicarbonate secretion in mice. *Gastroenterology* 125: 805–814.
- Uribe JM, Gelbmann CM, Traynor-Kaplan AE, Barrett KE (1996a). Epidermal growth factor inhibits Ca<sup>2+</sup>-dependent Cl<sup>-</sup> transport in T84 human colonic epithelial cells. *Am J Physiol* 271: C914–C922.
- Uribe JM, Keely SE, Traynor-Kaplan AE, Barrett KE (1996b). Phosphatidylinositol 3-Kinase mediates the inhibitory effect of epidermal growth factor on calcium-dependent chloride secretion. *J Biol Chem* 271: 26588–26595.
- Uribe JM, McCole DF, Barrett KE (2002). Interferon-gamma activates EGF receptor and increases TGF- $\alpha$  in T84 cells: implications for chloride secretion. *Am J Physiol* 283: G923–G931.
- Ussing HH, Zerahn K (1951). Active transport of sodium as the source of electric current in the short-circuited isolated frog skin. *Acta Physiol Scand* 23: 110–127.
- Vaandrager AB, Bajnath R, Groot JA, Bot AG, De Jonge HR (1991). Ca<sup>2+</sup> and cAMP activate different chloride efflux pathways in HT-29.c19A colonic epithelial cell line. *Am J Physiol* 261: G958–G965.
- Vajanaphanich M, Schultz C, Rudolf MT, Wasserman M, Enyedi P, Craxton A *et al.* (1994). Long-term uncoupling of chloride secretion from intracellular calcium levels by Ins(3,4,5,6)P<sub>4</sub>. *Nature* 371: 711–714.
- van den Berghe N, Vaandrager AB, Bot AG, Parker PJ, de Jonge HR (1992). Dual role for protein kinase C  $\alpha$  as a regulator of ion secretion in the HT29.c19A human colonic cell line. *Biochem J* 285 (Part 2): 673–679.
- Vanner S, MacNaughton WK (2004). Submucosal secretomotor and vasodilator reflexes. *Neurogastroenterol Motil* 16 (Suppl 1): 39–43.
- Venglarik CJ, Bridges RJ, Frizzell RA (1990). A simple assay for agonist-regulated Cl and K conductances in salt-secreting epithelial cells. *Am J Physiol* 259: C358–C364.
- Venkova K, Greenwood-van Meerveld B (2006). Long-lasting changes in small intestinal transport following the recovery from *Trichinella spiralis* infection. *Neurogastroenterol Motil* 18: 234–242.
- Wall SJ, Yasuda RP, Li M, Wolfe BB (1991). Development of an antisera against m3 muscarinic receptors: distribution of m3 receptors in rat tissues and clonal cell lines. *Mol Pharmacol* 40: 783–789.
- Wang H, Yu M, Ochani M, Amella CA, Tanovic M, Susarla S *et al.* (2003). Nicotinic acetylcholine receptor  $\alpha 7$  subunit is an essential regulator of inflammation. *Nature* 421: 384–388.
- Wess J (2004). Muscarinic acetylcholine receptor knockout mice: novel phenotypes and clinical implications. *Annu Rev Pharmacol Toxicol* 44: 423–450.
- Wessler I, Kilbinger H, Bittinger F, Unger R, Kirkpatrick CJ (2003). The non-neuronal cholinergic system in humans: expression, function and pathophysiology. *Life Sci* 72: 2055–2061.
- Yada T, Oiki S, Ueda S, Okada Y (1989). Intestinal secretagogues increase cytosolic free Ca<sup>2+</sup> concentration and K<sup>+</sup> conductance in a human intestinal epithelial cell line. *J Membr Biol* 112: 159–167.
- Yada T, Okada Y (1984). Electrical activity of an intestinal epithelial cell line: hyperpolarizing responses to intestinal secretagogues. *J Membr Biol* 77: 33–44.
- Yule DI, Essington TE, Williams JA (1993). Pilocarpine and carbachol exhibit markedly different patterns of Ca<sup>2+</sup> signaling in rat pancreatic acinar cells. *Am J Physiol* 264: G786–G791.
- Zhou X, Ren J, Brown E, Schneider D, Caraballo-Lopez Y, Galligan JJ (2002). Pharmacological properties of nicotinic acetylcholine receptors expressed by guinea pig small intestinal myenteric neurons. *J Pharmacol Exp Ther* 302: 889–897.
- Zimmerman TW, Binder HJ (1983). Effect of tetrodotoxin on cholinergic agonist-mediated colonic electrolyte transport. *Am J Physiol* 244: G386–G391.